

Foreword

Thank you for choosing Powtran PI500 Series Frequency Inverter. This product made by Powtran is based on years of experience in professional production and sale, and designed for variety of industrial machinery, fan and water pump drive unit and IF heavy-duty grinding unit.

This manual provides user the relevant precautions on installation, operational parameter setting, abnormal diagnosis, routine maintenance and safe use. In order to ensure correct installation and operation of the frequency converter, please carefully read this manual before installing it.

For any problem when using this product, please contact your local dealer authorized by this company or directly contact this company, our professionals are happy to serve you.

The end-users should hold this manual, and keep it well for future maintenance & care, and other application occasions. For any problem within the warranty period, please fill out the warranty card and fax it to the our authorized dealer.

The contents of this manual are subject to change without prior notice. To obtain the latest information, please visit our website.

For more product information, please visit: <http://www.powtran.com>.

Contents

Chapter 1	Inspection and safety precautions	1
1-1.	Inspection after unpacking	1
1-1-1.	Instructions on nameplate	1
1-1-2.	Model designation	1
1-2.	Safety precautions	2
1-3.	Precautions	4
1-4.	Scope of applications	6
Chapter 2	Standard specifications	7
2-1.	Technical specifications	7
2-2.	Special customized product specifications	11
2-3.	Standard specifications	12
Chapter 3	Keyboard	16
3-1.	Keyboard description	16
3-2.	Keyboard Indicators	16
3-3.	Description of operation panel keys	17
3-4.	Keyboard display letters and numbers correspondence table	17
3-5.	Examples of parameter settings	18
3-5-1.	Instructions on viewing and modifying function code	18
3-5-2.	The way to read parameters in various status	19
3-5-3.	Password settings	19
3-5-4.	Motor parameter auto turning	19
Chapter 4	Installation and commissioning	21
4-1.	Installation direction and space	21
4-2.	Wiring Diagram	22
4-2-1.	Wiring diagram	23
4-3.	Main circuit terminal	24
4-3-1.	Main circuit terminal arrangement	24
4-3-2.	Function description of main circuit terminal	28
4-3-3.	Varistor and safety capacitor switch	28
4-4.	Control circuit terminals	29
4-4-1.	Control circuit terminals arrangement	29
4-4-2.	Description of control circuit terminals	29
4-4-3.	Signal input terminal circuit	31
4-5.	Wiring Precautions	32
4-6.	Spare Circuit	33
4-7.	Commissioning	34
Chapter 5	Function parameter	35
5-1.	Menu grouping	35
5-1-1.	d0 Group - Monitoring function group	36
5-1-2.	F0 Group -Basic function group	37
5-1-3.	F1 Group - Input terminals group	39
5-1-4.	F2 Group - Output terminals group	44
5-1-5.	F3 Group - Start and stop control group	47
5-1-6.	F4 Group - V/F control parameters	48
5-1-7.	F5 Group - Vector control parameters	49
5-1-8.	F6 Group - Keyboard and display	49

5-1-9. F7 Group - Auxiliary function group.....	51
5-1-10. F8 Group - Fault and protection.....	53
5-1-11. F9 Group - Communication parameter.....	55
5-1-12. FA Group - Torque control parameters.....	56
5-1-13. Fb group - Control optimization parameters.....	57
5-1-14. FC Group - Extended parameter group.....	57
5-1-15. E0 Group - Wobble, fixed-length and counting.....	57
5-1-16. E1 Group, Multi-speed, Simple PLC.....	58
5-1-17. E2 Group - PID function.....	60
5-1-18. E3 Group – Virtual DI、 Virtual DO.....	61
5-1-19. b0 Group -Motor parameters.....	62
5-1-20. y0 Group - Function code management.....	64
5-1-21. y1 Group -Fault query.....	64
Chapter 6 Troubleshooting.....	67
6-1. Fault alarm and countermeasures.....	67
6-2. EMC (Electromagnetic Compatibility).....	71
6-2-1. Definition.....	71
6-2-2. EMC standard.....	71
6-3. EMC directive.....	71
6-3-1. Harmonic effect.....	71
6-3-2. Electromagnetic interference and installation precautions.....	71
6-3-3. Remedies for the interference from the surrounding electromagnetic equipment to the inverter.....	72
6-3-4. Remedies for the interference from the inverter to the surrounding electromagnetic equipment.....	72
6-3-5. Remedies for leakage current.....	72
6-3-6. Precautions on installing EMC input filter at the input end of power supply.....	73
Chapter 7 Dimension.....	74
7-1. Dimension.....	74
7-1-1. Product outside drawing, installation size.....	74
7-1-2. PI500 series.....	74
7-1-3. Specification and type of special customized product.....	82
7-1-4. PI500 series (With DC reactor base).....	83
7-1-5. Keypad dimension drawing.....	86
Chapter 8 Maintenance and repair.....	88
8-1. Inspection and maintenance.....	88
8-2. Parts for regular replacement.....	88
8-3. Storage.....	89
8-4. Capacitor.....	89
8-4-1. Capacitor rebuilt.....	89
8-5. Measuring and readings.....	90
Chapter 9 Options.....	91
Chapter 10 Warranty.....	93
Appendix I RS485 Communication protocol.....	94
I-1 Communication protocol.....	94
I-1-1 Communication content.....	94
I-1-2 Protocol description.....	95
I-2 Check mode:.....	97
I-3 Definition of communication parameter address.....	98

Appendix II How to use universal encoder expansion card.....	103
II-1 Overview.....	103
II-2 Description of mechanical installation and control terminals function.....	103
Appendix III CAN bus communication card use description.....	105
III-1.Overview.....	105
III-2.Mechanical installation and terminal functions.....	105
Appendix IV: Instruction of Profitbus –DP communication card.....	106
IV-1.Outline.....	106
IV-2 Terminal function.....	106
Appendix V Product application case.....	108
V-1. Single pump constant pressure water supply parameter setting.....	108
V-2 Terminal block control motor forward and reverse.....	109
V-3 External frequency table and ammeter.....	110
V-4 Terminal block control forward /reverse running jog.....	111
V-5 Multi-speed running.....	111
V-6 External potentiometer speed.....	112
V-7 Keyboard potentiometer speed.....	113
V-8.Rise / Fall Control Speed.....	113
V-9. External analog speed control (External 0 ~ 10V voltage signal given).....	114
V-10. External analog speed control (External 0 ~ 20mA current signal given).....	115
V-11. Air compressor constant pressure control (Sensor for two-wire pressure transmitter).....	116
V-12.Frequency reference mode(External potentiometer, keyboard encoder) switching.....	117

Chapter 1. Inspection and safety precautions

Powtran frequency inverters have been tested and inspected before leaving factory. After purchasing, please check if its package is damaged due to careless transportation, and if the specifications and model of the product are consistent with your order requirements. For any problem, please contact your local authorized Powtran dealer or directly contact this company.

1-1. Inspection after unpacking

※Check if that packing container contains this unit, one manual and one warranty card.

※Check the nameplate on the side of the frequency inverter to ensure that the product you have received is right the one you ordered.

1-1-1. Instructions on nameplate

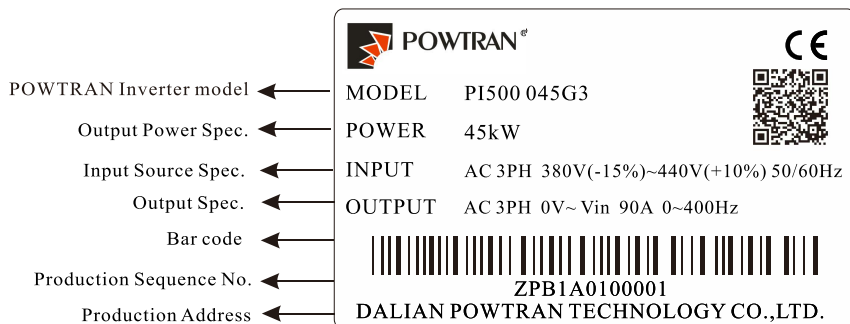

Figure 1-1: Nameplate description

1-1-2. Model designation

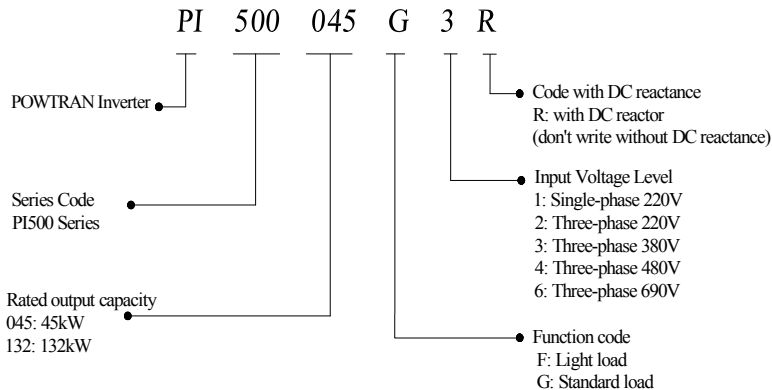











Figure 1-2: Model description





1-2.Safety precautions

Safety precautions in this manual are divided into the following two categories:

 **Danger:** The dangers caused by failure to perform required operation, may result in serious injury or even death;

 **Caution:**the dangers caused by failure to perform required operation, may result in moderate injury or minor injury, and equipment damage;

Process	Type	Explanation
Before installation	 Danger	<ul style="list-style-type: none"> ●When unpacking, if control system with water, parts missed or component damaged are found, do not install! ●If packing list does not match the real name, do not install!
When installing	 Danger	<ul style="list-style-type: none"> ● Gently carry with care, otherwise there is the risk of damage to equipment! ●Please do not use the damaged driver or the frequency inverter with missed pieces, otherwise there is the risk of injury! ●Do not use your hand to touch the control system components, otherwise there is the risk of electrostatic damage!
	 Note	<ul style="list-style-type: none"> ● Please install the unit on the metal or flame retardant objects; away from combustible material. Failure to do so may cause a fire! ● Never twist the mounting bolts of the equipment components, especially the bolt with the red mark!
When wiring	 Danger	<ul style="list-style-type: none"> ● Do not let the lead wires or screws fall into the driver. Otherwise which may cause damage to the driver! ● Keep the driver installed in the place where less vibration, avoid direct sunlight. ● When two or more converters are installed in a cabinet, please pay attention to the installation location, ensure the good heat dissipation effect.
Before energizing	 Note	<ul style="list-style-type: none"> ● Must comply with this manual's guidance, any construction shall be performed by a professional electrician, otherwise there would be the unexpected risk ! ● A circuit breaker must be set between the inverter and the power supply to separate them, otherwise it may cause a fire!
	 Danger	<ul style="list-style-type: none"> ● Verify if power is a zero-energy status before wiring, otherwise there is a risk of electric shock! ● The inverter shall be grounded correctly according to standard specifications, otherwise there is a danger of electrical shock! ● Ensure that the distribution line meets the regional safety standards of EMC requirements. The diameter of used wire shall refer to the recommendations of this manual. Otherwise it may cause an accident! ● Never directly connect braking resistor to the DC bus P(+) and P(-) terminals. Otherwise it may cause a fire! ● Encoder must use the shielded wire, and the shielding layer must ensure the single-ended grounded!
After energizing	 Danger	<ul style="list-style-type: none"> ● Please confirm whether the input power voltage is same as the inverter rated voltage; wiring positions of power input terminals(R, S, T) and output terminals(U, V, W) are correct or not; and note

Process	Type	Explanation
		<p>that if there is a short circuit in the peripheral circuit connected to driver, if the connected lines are tight, otherwise it may cause damage to the driver!</p> <ul style="list-style-type: none"> Do not need to perform withstand voltage test for any part of the inverter, this product has been tested before leaving factory. Otherwise it may cause an accident!
During operation	 Danger	<ul style="list-style-type: none"> The inverter's cover plate must be closed before power on. Otherwise it may cause an electric shock! Wiring of all external accessories must comply with the guidance of this manual, please correctly wiring in accordance with the circuit connection methods described in this manual. Otherwise it may cause an accident!
	 Note	<ul style="list-style-type: none"> Do not open cover plate after energizing. Otherwise there is a risk of electric shock! Do not touch the driver and peripheral circuits with wet hands. Otherwise there is a risk of electric shock! Do not touch any input and output terminals of the inverter. Otherwise there is a risk of electric shock! The inverter automatically perform the safety testing for the external strong electrical circuit in the early stages of energizing, therefore never touch the driver terminals(U, V, W) or motor terminals, otherwise there is a risk of electric shock! If you need to identify the parameters, please pay attention to the danger of injury during motor rotation. Otherwise it may cause an accident! Please do not change the inverter manufacturer parameters. Otherwise it may cause damage to this unit!
When maintaining	 Danger	<ul style="list-style-type: none"> Do not touch the cooling fan and the discharge resistor to feel the temperature. Otherwise it may cause burns! Non-professional personnel is not allowed to detect signal when operating. Doing so may cause personal injury or damage to this unit!
	 Note	<ul style="list-style-type: none"> When the inverter is operating, you should avoid that objects fall into this unit. Otherwise cause damage to this unit! Do not start/stop the driver by switching on/off contactor. Otherwise cause damage to this unit!
During maintenance	 Danger	<ul style="list-style-type: none"> Do not perform repairs and maintenance for the live electrical equipment. Otherwise there is a risk of electric shock! The repairs and maintenance task can be performed only when the inverter bus voltage is lower than 36V, Otherwise, the residual charge from capacitor would cause personal injury! Non-well-trained professional personnel is not allowed to perform repairs and maintenance of inverter. Doing this may cause personal injury or damage to this unit! After replacing the inverter, parameter settings must be redone, all pluggable plugs can be operated only in the case of powering off!

1-3.Precautions

No.	Type	Explanation
1	Motor insulation inspection	Please perform motor insulation inspection for the first time use, re-use after leaving unused for a long time as well as regular check, in order to prevent damage to the inverter because of the motor's winding insulation failure. Wiring between motor and inverter shall be disconnected, it is recommended that the 500V voltage type megger should be adopted and insulation resistance shall be not less than 5MΩ.
2	Motor thermal protection	If the rated capacity of the selected motor does not match the inverter, especially when the inverter rated power is greater than the motor rated power, be sure to adjust the motor protection parameter values inside inverter or install thermal relay in the front of motor for motor protection.
3	Run over power frequency	The inverter output frequency rang is 0Hz~3200Hz(Max.vector control only supports 300Hz). If the user is required to run at 50Hz or more, please consider the endurance of your mechanical devices.
4	Vibrations of mechanical device	Inverter output frequency may be encountered mechanical resonance point of the load device, you can set jump frequency parameter inside inverter to avoid the case.
5	Motor heat and noise	The inverter output voltage is PWM wave that contains a certain amount of harmonics, so the temperature rise, noise and vibration of motor show a slight higher than frequency power frequency operation.
6	Output side with piezoresistor or capacitor for proving power factor	The inverter output is PWM wave, if the piezoresistor for lightning protection or the capacitor for improving power factor is installed in the output side, which easily cause the inverter instantaneous overcurrent or even cause damage to the inverter. Please do not use.
7	Contact or switch used in the inverter input/output terminals	If contactor is installed between power supply and inverter, the contactor is not allowed to start/stop the inverter. Necessarily need to use the contactor to control the inverter start/stop, the interval should not be less than one hour. Frequent charging and discharging may reduce the service life of the inverter capacitor. If the contactor or switch is equipped between output terminals and motor, the inverter should be turned on/off without output status, otherwise which easily lead to damage to the inverter module.
8	Use other than the rated voltage	PI series inverter is not suitable for use beyond the allowable operating voltage described in this manual, which easily cause damage to the parts inside inverter. If necessary, please use the corresponding transformer to change voltage.
9	Never change 3-phase input to 2-phase input	Never change PI series 3-phase inverter to 2-phase one for application. Otherwise it will lead to malfunction or damage to the inverter.
10	Lightning	The series inverter is equipped with lightning overcurrent protection

No.	Type	Explanation
	surge protection	device, so it has the ability of self-protection to lightning induction. For the area where lightning is frequent, user should also install the extra protection in the front of the inverter.
11	High altitude and derating application	When the inverter is used in areas over 1000m altitude, it is required to reduce frequency because the thin air will decrease the cooling effect of inverter. Please consult our technician for details on the application.
12	Special use	If the user need to use methods other than the suggested wiring diagram provided in this manual, such as common DC bus, please consult our technician.
13	Precautions for scrap disposal of the inverter	When electrolytic capacitors on the main circuit and printed circuit board as well as plastic parts are burned, it may produce toxic gases. Please disposing as industrial waste.
14	Adaptive motor	<p>1) The standard adaptive motor is a four pole squirrel cage asynchronous induction motor. If the motor is not mentioned above, please select the frequency converter according to the rated current of the motor.</p> <p>2) The cooling fan and the rotor shaft for non-inverter motor are coaxially connected, the fan cooling effect is reduced when the rotational speed is reduced, therefore, when the motor works in overheating occasions, a strong exhaust fan should be retrofitted or replace non-inverter motor with the inverter motor.</p> <p>3) The inverter has built-in the adaptive motor standard parameters, according to the actual situation, please identify motor parameters or accordingly modify the default values to try to meet the actual value, otherwise it will operation affect and protection performance;</p> <p>4) When short-circuit of cable or motor internal will activate the inverter alarm, even bombing. Therefore, firstly perform insulation short-circuit test for the initial installation of the motor and cable, routine maintenance often also need to perform such test. Note that the parts to be tested and the inverter shall be disconnected completely when testing.</p>
15	Others	<p>1) We need to fix cover and lock before power on, so as to avoid the harm to personal safety that is caused by internal injuries of bad capacitors and other components.</p> <p>2) Do not touch internal circuit board and any parts after powering off and within five minutes after keyboard indicator lamp goes out, you must use the instrument to confirm that internal capacitor has been discharged fully, otherwise there is a danger of electric shock.</p> <p>3) Body static electricity will seriously damage the internal MOS field-effect transistors, etc., if there are not anti-static measures, do not touch the printed circuit board and IGBT internal device with hand, otherwise it may cause a malfunction.</p> <p>4) The ground terminal of the inverter (E or $\frac{1}{2}$) shall be earthed firmly according to the provisions of the National Electrical Safety and other relevant standards. Do not shut down (Power off) by pulling switch, and only cut off the power until the motor stopping operation.</p> <p>5) It is required to add the optional input filter attachment so as to meet CE standards.</p>

1-4.Scope of applications

※The frequency converter is suitable for three-phase AC asynchronous motor.

※This inverter can only be used in those occasions recognized by this company, an unapproved use may result in fire, electric shock, explosion and other accidents.

※If the inverter is used in such equipment (e.g: Equipment for lifting persons, aviation systems, safety equipment, etc.) and its malfunction may result in personal injury or even death. In this case, please consult the manufacturer for your application.

Only the well-trained personnel can be allowed to operate this unit, please carefully read the instructions on safety, installation, operation and maintenance before use.

The safe operation of this unit depends on proper transport, installation, operation and maintenance!

Chapter 2 Standard specifications

2-1. Technical specifications

Model	Rated output power(kW)	Rated input current(A)	Rated output current(A)	Adaptive motor(kW)
AC 1PH 220V(-15%)~240V(+10%)				
PI500 0R4G1	0.4	5.4	2.5	0.4
PI500 0R7G1	0.75	8.2	4	0.75
PI500 1R5G1	1.5	14	7	1.5
PI500 2R2G1	2.2	23	10	2.2
PI500 004G1	4.0	35	16	4.0
PI500 5R5G1	5.5	50	25	5.5
AC 3PH 220V(-15%)~240V(+10%)				
PI500 0R4G2	0.4	4.1	2.5	0.4
PI500 0R7G2	0.75	5.3	4	0.75
PI500 1R5G2	1.5	8.0	7	1.5
PI500 2R2G2	2.2	11.8	10	2.2
PI500 004G2	4.0	18.1	16	4
PI500 5R5G2	5.5	28	25	5.5
PI500 7R5G2	7.5	37.1	32	7.5
PI500 011G2	11	49.8	45	11
PI500 015G2	15.0	65.4	60	15.0
PI500 018G2	18.5	81.6	75	18.5
PI500 022G2	22.0	97.7	90	22.0
PI500 030G2	30.0	122.1	110	30.0
PI500 037G2	37.0	157.4	152	37.0
PI500 045G2	45.0	185.3	176	45.0
PI500 055G2	55.0	214	210	55.0
PI500 075G2	75	307	304	75
PI500 093G2	93	383	380	93
PI500 110G2	110	428	426	110
PI500 132G2	132	467	465	132
PI500 160G2	160	522	520	160
AC 3PH 380V(-15%)~440V(+10%)				
PI500 0R7G3	0.75	4.3	2.5	0.75

Model	Rated output power(kW)	Rated input current(A)	Rated output current(A)	Adaptive motor(kW)
PI500 1R5G3	1.5	5.0	3.8	1.5
PI500 2R2G3	2.2	5.8	5.1	2.2
PI500 004G3	4.0	10.5	9	4.0
PI500 5R5G3	5.5	14.6	13	5.5
PI500 7R5G3	7.5	20.5	17	7.5
PI500 011F3	11	26	25	11
PI500 011G3	11	26	25	11
PI500 015F3	15	35	32	15
PI500 015G3/018F3	15/18.5	35/38.5	32/37	15/18.5
PI500 018G3/022F3	18.5/22	38.5/46.5	37/45	18.5/22
PI500 022G3	22	46.5	45	22
PI500 030F3	30	62	60	30
PI500 030G3	30	62	60	30
PI500 037F3	37	76	75	37
PI500 037G3/045F3	37/45	76/91	75/90	37/45
PI500 045G3	45	91	90	45
PI500 055F3	55	112	110	55
PI500 055G3	55	112	110	55
PI500 075F3	75	157	150	75
PI500 075G3	75	157	150	75
PI500 093F3	93	180	176	93
PI500 093G3/110F3	93/110	180/214	176/210	93/110
PI500 110G3/132F3	110/132	214/256	210/253	110/132
PI500 132G3	132	256	253	132
PI500 160F3	160	307	304	160
PI500 160G3/187F3	160/187	307/345	304/340	160/187
PI500 187G3/200F3	187/200	345/385	340/380	187/200
PI500 200G3/220F3	200/220	385/430	380/426	200/220
PI500 220G3	220	430	426	220
PI500 250F3	250	468	465	250
PI500 250G3/280F3	250/280	468/525	465/520	250/280
PI500 280G3	280	525	520	280
PI500 315F3	315	590	585	315

Model	Rated output power(kW)	Rated input current(A)	Rated output current(A)	Adaptive motor(kW)
PI500 315G3/355F3	315/355	590/665	585/650	315/355
PI500 355G3/400F3	355/400	665/785	650/725	355/400
PI500 400G3	400	785	725	400
AC 3PH 480V±10%				
PI500 0R7G4	0.75	4.1	2.5	0.75
PI500 1R5G4	1.5	4.9	3.7	1.5
PI500 2R2G4	2.2	5.7	5.0	2.2
PI500 004G4	4.0	9.4	8	4.0
PI500 5R5G4	5.5	12.5	11	5.5
PI500 7R5G4	7.5	18.3	15	7.5
PI500 011F4	11	23.1	22	11
PI500 011G4	11	23.1	22	11
PI500 015F4	15	29.8	27	15
PI500 015G4/018F4	15/18.5	29.8/35.7	27/34	15/18.5
PI500 018G4/022F4	18.5/22	35.7/41.7	34/40	18.5/22
PI500 022G4	22	41.7	40	22
PI500 030F4	30	57.4	55	30
PI500 030G4	30	57.4	55	30
PI500 037F4	37	66.5	65	37
PI500 037G4/045F4	37/45	66.5/81.7	65/80	37/45
PI500 045G4	45	81.7	80	45
PI500 055F4	55	101.9	100	55
PI500 055G4	55	101.9	100	55
PI500 075F4	75	137.4	130	75
PI500 075G4	75	137.4	130	75
PI500 093F4	93	151.8	147	93
PI500 093G4/110F4	93/110	151.8/185.3	147/180	93/110
PI500 110G4/132F4	110/132	185.3/220.7	180/216	110/132
PI500 132G4	132	220.7	216	132
PI500 160F4	160	264.2	259	160
PI500 160G4/187F4	160/187	264.2/309.4	259/300	160/187
PI500 187G4/200F4	187/200	309.4/334.4	300/328	187/200
PI500 200G4/220F4	200/220	334.4/363.9	328/358	200/220

Model	Rated output power(kW)	Rated input current(A)	Rated output current(A)	Adaptive motor(kW)
PI500 220G4	220	363.9	358	220
PI500 250F4	250	407.9	400	250
PI500 250G4/280F4	250/280	407.9/457.4	400/449	250/280
PI500 280G4	280	457.4	449	280
PI500 315F4	315	533.2	516	315
PI500 315G4/355F4	315/355	533.2/623.3	516/570	315/355
PI500 355G4/400F4	355/400	623.3/706.9	570/650	355/400
PI500 400G4	400	706.9	650	400
AC 3PH 690V±10%				
PI500 011G6/015F6	11/15	15/20	12/15	11/15
PI500 015G6/018F6	15/18.5	20/30	15/20	15/18.5
PI500 018G6/022F6	18.5/22	30/35	20/24	18.5/22
PI500 022G6/030F6	22/30	35/45	24/33	22/30
PI500 030G6/037F6	30/37	45/55	33/41	30/37
PI500 037G6/045F6	37/45	55/65	41/50	37/45
PI500 045G6/055F6	45/55	65/70	50/62	45/55
PI500 055G6/075F6	55/75	70/90	62/85	55/75
PI500 075G6/093F6	75/93	90/105	85/102	75/93
PI500 093G6	93	105	102	93
PI500 110F6	110	130	125	110
PI500 110G6/132F6	110/132	130/170	125/150	110/132
PI500 132G6/160F6	132/160	170/200	150/175	132/160
PI500 160G6/187F6	160/187	200/210	175/198	160/187
PI500 187G6/200F6	187/200	210/235	198/215	187/200
PI500 200G6/220F6	200/220	235/247	215/245	200/220
PI500 220G6/250F6	220/250	247/265	245/260	220/250
PI500 250G6/280F6	250/280	265/305	260/299	250/280
PI500 280G6/315F6	280/315	305/350	299/330	280/315
PI500 315G6/355F6	315/355	350/382	330/374	315/355
PI500 355G6/400F6	355/400	382/435	374/410	355/400
PI500 400G6/450F6	400/450	435/490	410/465	400/450

Note:

(1)PI500 frequency converter PI500 132G3 / PI500 160F3 ~ PI500 630G3 with "R" indicates DC reactor, such as PI500 160G3R,PI500 160G4R.

(2) The correct selection method of frequency converter is: the rated output current of

frequency converter is greater than or equal to the rated current of motor, and the overload capacity is considered; the difference between the rated power of frequency converter and motor is generally recommended not to exceed two power sections; when large frequency converter is equipped with small motor, it is necessary to input motor parameters accurately to avoid motor overload and damage.

2-2.Special customized product specifications

Model	Rated output power(kW)	Rated input current(A)	Rated output current(A)	Adaptive motor(kW)
AC 3PH 380V(-15%)~440V(+10%)				
PI500 030G3B	30	62	60	30
PI500 037G3B	37	76	75	37
PI500 045G3B	45	91	90	45
PI500 055F3N	55	112	110	55
PI500 055G3B	55	112	110	55
PI500 075G3B	75	157	150	75
PI500 450F3R	450	883	820	450
PI500 450G3R/500F3R	450/500	883/920	820/860	450/500
PI500 500G3R/560F3R	500/560	920/1010	860/950	500/560
PI500 560G3R/630F3R	560/630	1010/1160	950/1100	560/630
PI500 630G3R/700F3R	630/700	1160/1310	1100/1250	630/700
AC 3PH 480V±10%				
PI500 030G4B	30	57.4	55	30
PI500 037G4B	37	66.5	65	37
PI500 045G4B	45	81.7	80	45
PI500 055F4N	55	101.9	100	55
PI500 055G4B	55	101.9	100	55
PI500 075G4B	75	137.4	130	75

Note:

(1) Supplement our standard machine 30-75kw with built-in brake unit, suffix model g3b / F3B / f4b / G4B.

(2) "N" refers to the abbreviation of "non standard", it mainly refers to non-standard customization machine, the cost or performance is customized according to the field use, please consult the pre-sales service for specific selection.

(3) The specific installation dimensions of the above machines are detailed in Chapter 7.

2-3. Standard specifications

Items		Specifications	
Power Input	Rated voltage	AC 1PH 220V(-15%)~240V(+10%) AC 3PH 220V(-15%)~240V(+10%) AC 3PH 380V(-15%)~440V(+10%) AC 3PH 480V(-10%)~480V(+10%) AC 3PH 690V(-10%)~690V(+10%)	
	Input frequency	50Hz/60Hz	
	Allowing fluctuations	Voltage continued volatility:±10%	Less than 3% of voltage unbalance rate 3%;
		Input frequency fluctuation:±5%;	Distortion satisfy IEC61800-2 standard
Control system	Control system	High performance vector control inverter based on DSP	
	Control method	V/F control, vector control W/O PG, vector control W/ PG	
	Automatic torque boost function	Realize low frequency (1Hz) and large output torque control under the V/F control mode.	
	Acceleration/deceleration control	Straight or S-curve mode. Four times available and time range is 0.0~6500.0s.	
	V/F curve mode	Linear, square root/m-th power, custom V/F curve	
	Over load capability	G type:rated current 150% - 1 minute, rated current 180% - 2 seconds F type:rated current 120% - 1 minute, rated current 150% - 2 seconds	
	Maximum frequency	1、 Vector control:0~300Hz; 2、 V/F control:0~3200Hz	
	Carrier Frequency	0.5~16kHz; automatically adjust carrier frequency according to the load characteristics.	
	Input frequency resolution	Digital setting: 0.01Hz minimum analog: 0.01Hz.	
	Start torque	G type: 0.5Hz/150% (Vector control W/O PG) F type: 0.5Hz/100% (Vector control W/O PG)	
	Speed range	1:100 (Vector control W/O PG) 1:1000 (Vector control W/ PG)	
	Steady-speed precision	Vector control W/O PG: $\leq \pm 0.5\%$ (Rated synchronous speed) Vector control W/ PG: $\leq \pm 0.02\%$ (Rated synchronous speed)	
	Torque response	$\leq 40\text{ms}$ (Vector control W/O PG)	
	Torque boost	Automatic torque boost; manual torque boost(0.1%~30.0%)	
	DC braking	DC braking frequency: 0.0Hz~max. Frequency, braking time: 0.0~100.0 seconds, braking current value: 0.0%~100.0%	
	Jogging control	Jog Frequency Range: 0.00Hz~max. Frequency; Jog Ac/deceleration time: 0.0~6500.0s	
	Multi-speed operation	Achieve up to 16-speed operation through the control terminal	
Built-in PID	Easy to realize closed-loop control system for the process control.		
Automatic voltage regulation(AVR)	Automatically maintain a constant output voltage when the voltage of electricity grid changes		

Items		Specifications	
	Torque limit and control	"Excavator" feature - torque is automatically limited during the operation to prevent frequent overcurrent trip; the closed-loop vector mode is used to control torque.	
Personalization function	Self-inspection of peripherals after power-on	After powering on, peripheral equipment will perform safety testing, such as ground, short circuit, etc.	
	Common DC bus function	Multiple inverter can use a common DC bus.	
	Quick current limiting	The current limiting algorithm is used to reduce the inverter over current probability, and improve whole unit anti-interference capability.	
	Timing control	Timing control function: Time setting range(0m~6500m)	
Running	Input signal	Running method	Keyboard/terminal/communication
		Frequency setting	10 frequency settings available, including adjustable DC(0~10V/-10~+10V), adjustable DC(0~20mA), panel potentiometer, etc.
		Start signal	Rotate forward/reverse
		Multi-speed	At most 16-speed can be set(Run by using the multi-function terminals or program)
		Emergency stop	Interrupt controller output
		Wobble run	Process control run
		Fault reset	When the protection function is active, you can automatically or manually reset the fault condition.
		PID feedback signal	Including DC(0~10V), DC(0~20mA)
	Output Signal	Running status	Motor status display, stop, ac/deceleration, constant speed, program running status.
		Fault output	Contact capacity :normally closed contact 3A/AC 250V,normally open contact5A/AC 250V,1A/DC 30V.
		Analog output	Two-way analog output, 16 signals can be selected such as frequency, current, voltage and other, output signal range (0~10V / 0~20mA).
		Output signal	At most 4-way output, there are 40 signals each way
	Run function	Limit frequency, jump frequency, frequency compensation, auto-tuning, PID control	
	DC current braking	Built-in PID regulates braking current to ensure sufficient braking torque under no overcurrent condition.	
	Running command channel	Three channels: Operation panel, control terminals and serial communication port. They can be switched through a variety of ways.	
	Frequency source	Total 10 frequency sources: Digital, analog voltage, analog current, multi-speed and serial port. They can be switched through a variety of ways.	
Input terminals	8 digital input terminals, compatible with active PNP or NPN input mode, one of them can be for high-speed pulse input(0~100 kHz square wave); 3 analog input terminals for voltage or current input.		
Output terminals	2 digital output terminals, one of them can be for high-speed pulse		

Items		Specifications	
		output(0~100kHz square wave); one relay output terminal; 2 analog output terminals respectively for optional range (0~20mA / 0~10V), they can be used to set frequency, output frequency, speed and other physical parameters.	
Protection function	Inverter protection	Overvoltage protection, undervoltage protection, overcurrent protection, overload protection, overheat protection, overcurrent stall protection, overvoltage stall protection, losing-phase protection (Optional), communication error, PID feedback signal abnormalities, PG failure and short circuit to ground protection.	
	IGBT temperature display	Displays current temperature IGBT	
	Inverter fan control	Can be set	
	Instantaneous power-down restart	Less than 15 milliseconds: Continuous operation. More than 15 milliseconds: Automatic detection of motor speed, instantaneous power-down restart.	
	Speed start tracking method	The inverter automatically tracks motor speed after it starts	
	Parameter protection function	Protect inverter parameters by setting administrator Password and decoding	
Display	LED/OL ED display keyboard	Running information	Monitoring objects including: Running frequency, set frequency, bus voltage, output voltage, output current, output power, output torque, input terminal status, output terminal status, analog AI1 value, analog AI2 value, motor Actual running speed,PID set value percentage, PID feedback value percentage.
		Error message	At most save three error message, and the time, type, voltage, current, frequency and work status can be queried when the failure is occurred.
	LED display	Display parameters	
	OLED display	Optional, prompts operation content in Chinese/English text.	
	Copy parameter	Can upload and download function code information of frequency converter, rapid replication parameters.	
	Key lock and function selection	Lock part or all of keys, define the function scope of some keys to prevent misuse.	
	Communication	RS485	The optional completely isolated RS485 communication module can communicate with the host computer.
Environment Product standard	Environment temperature	-10to 40℃ (The environment temperature in 40 ~ 50 ℃, please derating use)	
	Storage temperature	-20~65 ℃	
	Environment humidity	Less than 90% R.H, no condensation.	
	Vibration	Below 5.9m/s ² (= 0.6g)	
	Application sites	Indoor where no sunlight or corrosive, explosive gas and water vapor, dust, flammable gas,oil mist, water vapor, drip or salt, etc.	

Items		Specifications
	Altitude	No need derating below 1000m, please derating 1% every 100 m when the altitude is above 3000m
	Protection level	IP20
Product standard	Product adopts safety standards.	IEC61800-5-1
	Product adopts EMC standards.	IEC61800-3
Cooling method		Forced air cooling

Chapter 3 Keyboard

3-1.Keyboard description











Figure 3-1:Operation panel display































3-2.Keyboard Indicators

Indicator flag		Name		
Status lamp	RUN	Running indicator light * ON: The inverter is working * OFF: The inverter stops		
	LOCAL/REMOTE	Command indicator light That is the indicator for keyboard operation, terminal operation and remote operation (Communication control) * ON: Terminal control working status * OFF: Keyboard control working status * Flashing: Remote control working status		
	FWD/REV	Forward/reverse running light * ON: in forward status * OFF: in reversal status		
	TUNE/TC	Motor self-learning/Torque control/Fault indicator * ON: in torque control mode * Slow flashing: in the motor tuning status * Quick flashing: in the fault status		
Units combination indicator	HzAV	<input type="checkbox"/> Hz <input type="checkbox"/> RPM <input type="checkbox"/> A <input type="checkbox"/> % <input type="checkbox"/> V	Hz	frequency unit
			A	current unit
			V	voltage unit
			RPM	speed unit
			%	percentage

3-3. Description of operation panel keys

Sign	Name	Function
	Parameter Setting/Esc Key	* Enter into the modified status of main menu * Esc from functional parameter modification * Esc submenu or functional menu to status menu
	Shift Key	* Choose displayed parameter circularly under running or stop interface; choose parameter's modified position when modify parameter
	Increasing Key	Parameter or function number increasing, set by parameter F6.18.
	Decreasing key	Parameter or function number decreasing, set by parameter F6.19.
	Running key	For starting running in the mode of keyboard control status
	Stop/Reset Key	* For stopping running in the running status; for resetting the operation in fault alarm status. The function of the key is subject to F6.00
	Enter key	Enter into levels of menu screen confirm setting
	Quick multifunction key	This key function is determined by the function code F6.21.
	Keyboard encoder	* In query status, function parameter increasing or decreasing * In modified status, the function parameter or modified position increasing or decreasing. * In monitoring status, frequency setting increasing or decreasing

3-4. Keyboard display letters and numbers correspondence table

Digital display area	Display letters	Corresponding letters	Display letters	Corresponding letters	Display letters	Corresponding letters
		0		1		2
		3		4		5
		6		7		8
		9		A		B
		C		d		E
		F		H		I
		L		N		n
		o		P		r
		S		t		U
		T		.		-
		y				

3-5.Examples of parameter settings

3-5-1.Instructions on viewing and modifying function code

PI500 inverter's operation pane is three levels menu for parameter setting etc.Three levels: function parameter group (Level 1)→function code(level 2)→function code setting(level 3). The operation is as following:

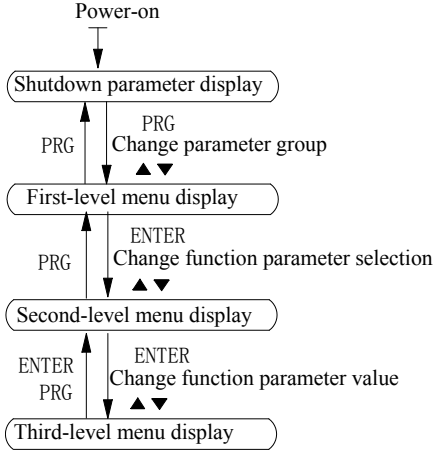
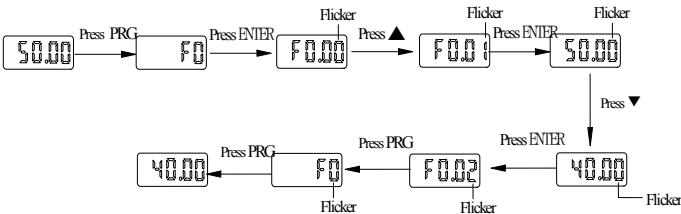

Figure 3-2:Operation processes

Description: Back to the level 2 menu from level 3 menu by PRG key or ENTER key in the level 3 operation status. The differences between the two keys : ENTER will be back to the level 2 menu and save parameter setting before back, and transfer to the next function code automatically; PRG will be back to the level 2 menu directly, not save parameter setting, then back to current function code.

Example 1 Frequency setting to modify parameters

Set F0.01 from 50.00Hz~40.00Hz



Example 2 :Restore factory settings

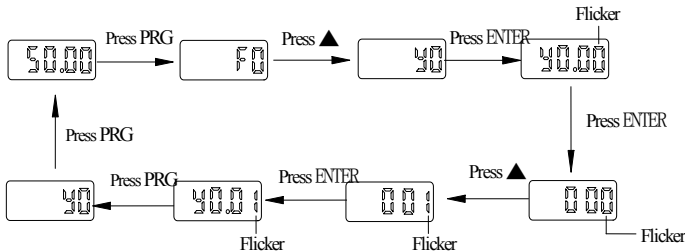

Without twinkling parameter position, the function code can not be modified in the level 3 menu. The reason maybe as following:

- 1) The function code can not be modified itself, eg: Actual detecting parameters, running record parameters.
- 2) The function code can not be modified in the running status. It must be modified in the stop status.

3-5-2.The way to read parameters in various status

In stop or run status, operate shift key  to display a variety of status parameters respectively. Parameter display selection depends on function code F6.01 (Run parameter 1), F6.02 (Run parameter 2) and F6.03 (Stop parameter 3).

In stop status, there are total 16 stop status parameters that can be set to display/not display: Set frequency, bus voltage, DI input status, DO output status, analog input AI1 voltage, analog input AI2 voltage, panel potentiometer input voltage, Actual count value, Actual length value, PLC running step number, Actual speed display, PID settings, high-speed pulse input frequency and reserve, switch and display the selected parameter by pressing key orderly.

In running status, there are 5 running-status parameters:running frequency,setting frequency,bus voltage,output voltage, output current default display, and other display parameters: Output power, output torque, DI input status, DO output status, analog input AI1 voltage, analog input AI2 voltage, panel potentiometer input voltage, Actual count value, Actual length value, linear speed, PID settings and PID feedback, etc, their display depends on function code F6.01 and F6.02 switch and display the selected parameter by pressing key orderly.

Inverter powers off and then powers on again, the displayed parameters are the selected parameters before power-off.

3-5-3.Password settings

The inverter has password protection. When y0.01 become not zero, it is the password and will be work after exit from function code modified status. Press PRG key again, will display"----". One must input the correct password to go to regular menu, otherwise, inaccessible.

To cancel the password protection function, firstly enter correct password to access and then set y0.01 to 0.

3-5-4.Motor parameter auto turning

Choose vector control, one must input the motor's parameters in the nameplate accurately before running the inverter. PI500 series frequency inverter will match the motor's standard parameters according to its nameplate. The vector control is highly depend on motor's parameters. The parameters of the controlled motor must be inputted accurately for the good control performance.

Motor parameter auto tuning steps are as follows:

Firstly select command source (F0.11=0) as the comment channel for operation panel, then input the following parameters according to the actual motor parameters (Selection is based on the current motor):

Motor Selection	Parameters	
Motor	b0.00: Motor type selection	b0.03: Motor rated current
	b0.01: Motor rated power	b0.04: Motor rated frequency
	b0.02: Motor rated voltage	b0.05: Motor rated speed

For asynchronous motors

If the motor can NOT completely disengage its load, please select 1 (asynchronous motor parameter static auto turning) for b0.27, and then press the RUN key on the keyboard panel.

If the motor can completely disengage its load, please select 2 (asynchronous motor parameter comprehensive auto turning) for b0.27, and then press the RUN key on the keyboard panel, the inverter will automatically calculate the motor's following parameters:

Motor Selection	Parameters	
Motor	b0.06:Asynchronous motor stator resistance	b0.09:Asynchronous motor mutual inductance
	b0.07:Asynchronous motor rotor resistance	b0.10:Asynchronous motor no-load current
	b0.08:Asynchronous motor leakage inductance	

Complete motor parameter auto turning

Chapter 4 Installation and commissioning

4-1. Installation direction and space

PI500 series inverter according to different power rating, the requirements of around installation reserve space is different, specifically as shown below:

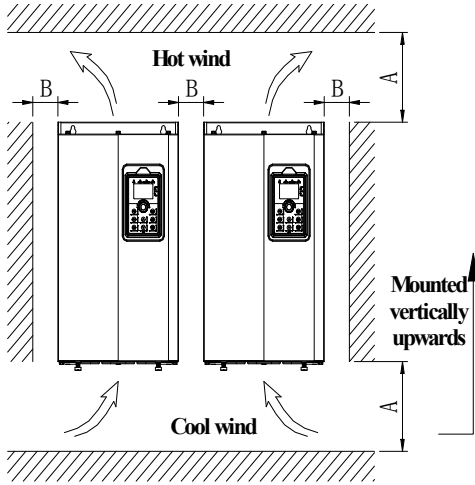

Power rating	Dimension requirement
0.75~11kW	$A \geq 100\text{mm}; B \geq 10\text{mm}$
15~22kW	$A \geq 200\text{mm}; B \geq 10\text{mm}$
30~75kW	$A \geq 200\text{mm}; B \geq 50\text{mm}$
93~400kW	$A \geq 300\text{mm}; B \geq 50\text{mm}$

Figure 4-1: PI500 Series Each power level installation space requirement

PI500 Series frequency inverter heat radiator circulated from bottom to top, when more than one inverter work together, usually mounted side by side. In the case of the need to install them by upper and lower rows, due to the heat of the lower inverters rising to the upper equipment, fault maybe caused, heat insulation deflector and other objects to be installed.

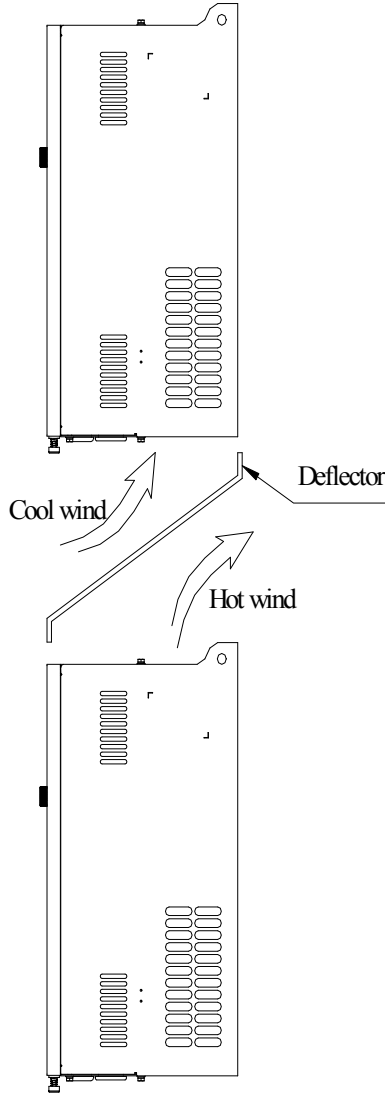

Figure 4-2: Heat insulation deflector up and down installation diagram

4-2.Wiring Diagram

Frequency inverter wiring is divided by main circuit and control circuit. Users must properly connect frequency inverter in accordance with the wiring connection diagram showing below.

4-2-1. Wiring diagram

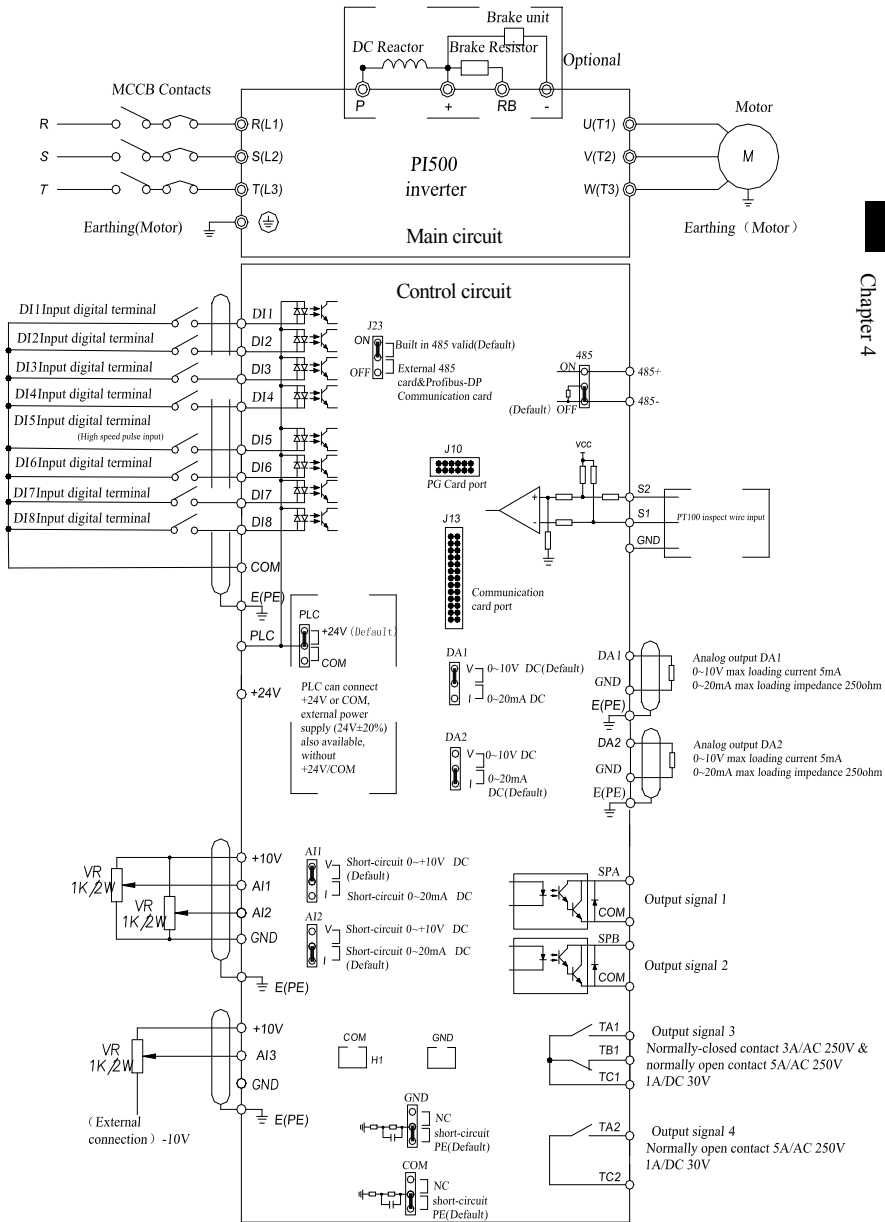

Figure 4-3: Wiring diagram

4-3.Main circuit terminal

4-3-1.Main circuit terminal arrangement

1.0.75~4kW G3 main circuit terminal (Moulded shell series)

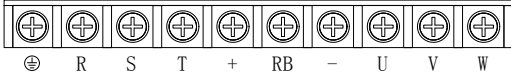

Figure 4-4: 0.75~4kW G3 main circuit terminal

2.5.5~11kW G3 main circuit terminal (Moulded shell series)

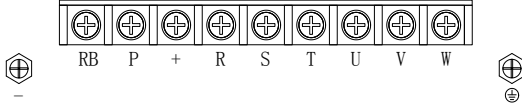

Figure 4-5: 5.5~11kW G3 main circuit terminal

3.15~22kW G3 main circuit terminal (Moulded shell series)

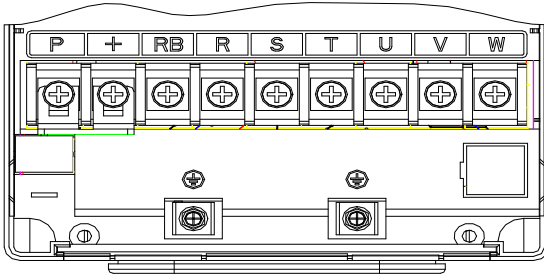

Figure 4-6: 15~22kW G3 main circuit terminal

4.30kW G3/F3 main circuit terminal

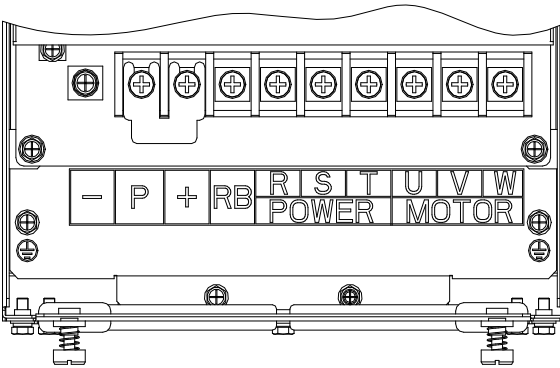

Figure 4-7: 30kW G3/F3 main circuit terminal

5.37kW G3/F3 main circuit terminal

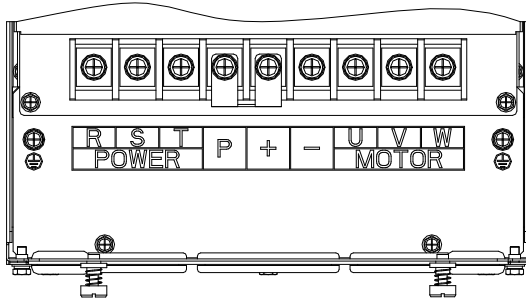

Figure 4-8: 37kW G3/F3 main circuit terminal

6.37~45kW G3B and 045G3 main circuit terminal

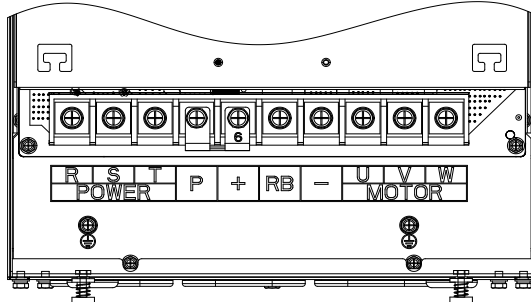

Figure 4-9: 37~45kW G3B and 045G3 main circuit terminal

7.55~75kW G3B main circuit terminal

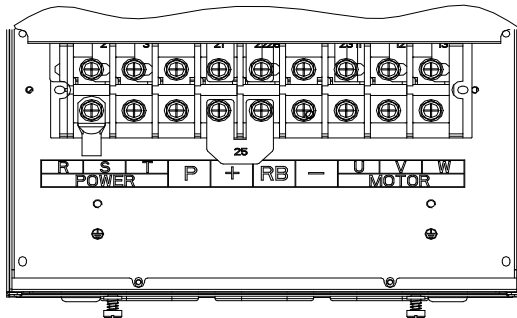

Figure 4-10: 55~75kW G3B main circuit terminal

8.55~75kW G3 main circuit terminal

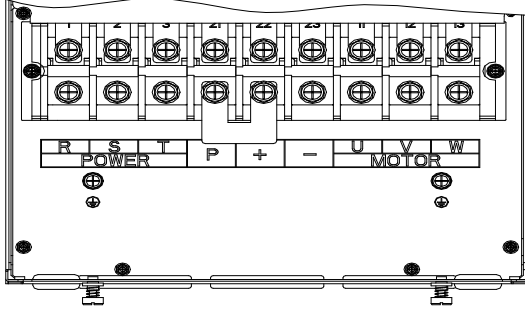

Figure 4-11: 55~75kW G3 main circuit terminal

9.93~160kW G3 main circuit terminal

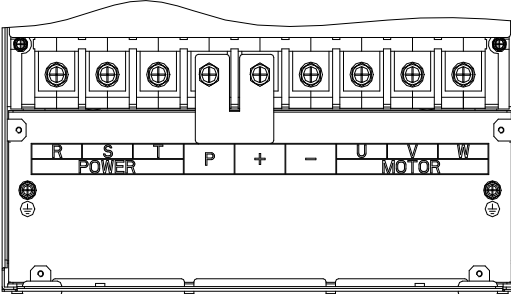

Figure 4-12: 93~160kW G3 main circuit terminal

10.160kW F3 main circuit terminal

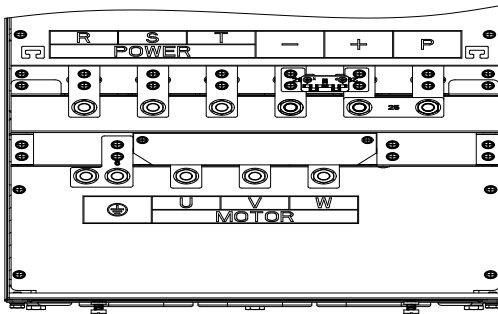

Figure 4-13: 160W F3 main circuit terminal

11.160~220kW G3 main circuit terminal

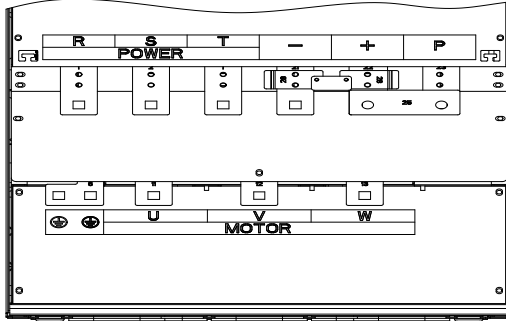

Figure 4-14: 160~220kW G3 main circuit terminal

12.250~400kW G3 main circuit terminal

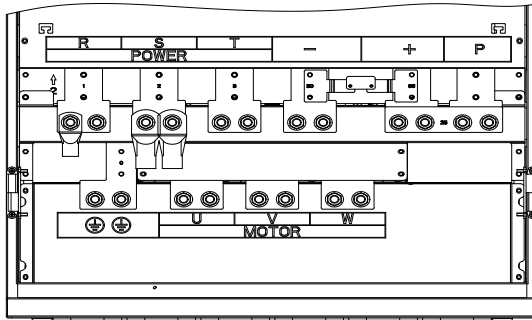

Figure 4-15: 250~400kW G3 main circuit terminal

13.450~630kW G3 main circuit terminal

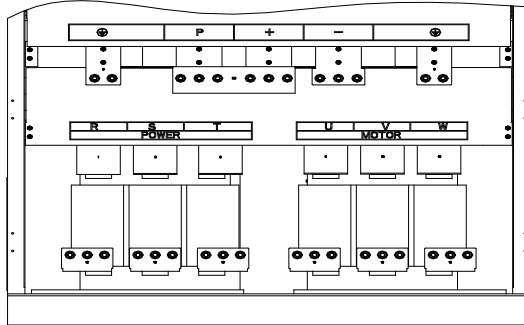

Figure 4-16: 450~630kW G3 main circuit terminal

Note: P/+ standard is circuit standard configuration is for the shorted state; if external DC reactor is connected, firstly disconnect and then reconnect.

4-3-2.Function description of main circuit terminal

Terminal	Name	Explain
R	Inverter input terminals	Connect to three-phase power supply, single-phase connects to R, T
S		
T		
⊕/PE	Ground terminals	Connect to ground
+, RB	Braking resistor terminals	Connect to braking resistor
U	Output terminals	Connect to three-phase motor(Please do not connect single phase motor)
V		
W		
+, -	DC bus output terminals	Connect to braking unit
P, +	DC reactor terminals	Connect to DC reactor(Remove the shorting block)

4-3-3.Varistor and safety capacitor switch

For the power grid system with neutral grounding, the customer needs to close the varistor switch (VDR) and safety capacitor switch (EMC) by himself (i.e. press the switch "I");

If it is used in it power grid system (neutral point to ground insulation or high impedance grounding), the varistor (VDR) to ground switch and the safety capacitor (EMC) to ground switch need to be disconnected, as shown in the figure below ("0" press down state is off state), and the filter cannot be installed, otherwise the inverter may be damaged.

In the case of configuration of residual current circuit breaker, if leakage protection occurs during starting, the safety capacitor (EMC) ground switch can be disconnected, as shown in the figure below.

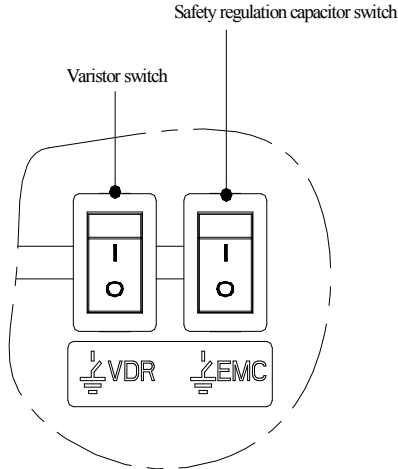

Figure 4-17: Schematic diagram of varistor switch (VDR) and safety capacitor switch (EMC)

4-4. Control circuit terminals

4-4-1. Control circuit terminals arrangement

1. Control panel control circuit terminals

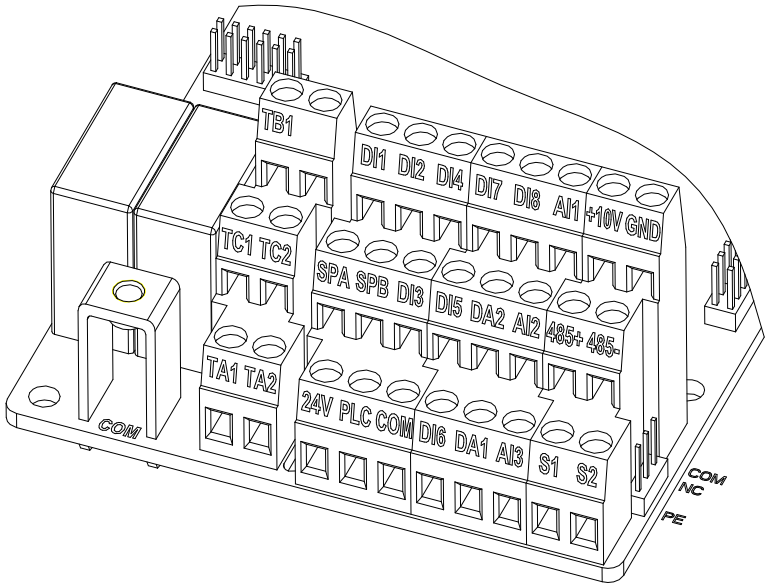

Figure 4-18: Control panel control circuit terminals

4-4-2. Description of control circuit terminals

Category	Symbol	Name	Function
Power supply	+10V-GND	+ 10V power supply	Output +10V power supply, maximum output current: 10mA Generally it is used as power supply of external potentiometer, potentiometer resistance range: 1~5kΩ
	+24V-COM	+24V power supply	Output +24V power supply, generally it is used as power supply of digital input and output terminals and external sensor. Maximum output current: 200mA
	PLC	External power input terminal	The use of external signal when driving, PLC to be connected with an external power supply, please unplug the PLC jumper. Factory default and +24V connection..
Analog input	AI1-GND	Analog input terminal 1	1. Input range: (DC 0~10V/0~20mA), depends on the selected AI1 jumper on control panel.

Category	Symbol	Name	Function
			2.Input impedance: 20kΩ with voltage input, 500Ω with current input.
	AI2-GND	Analog input terminal 2	1.Input range:(DC 0~10V/0to 20mA), depends on the selected AI2 jumper on control panel. 2.Input impedance: 20kΩ with voltage input, 500Ω with current input.
	AI3	Analog input terminal 3	1, Input range:DC-10~-+10V 2, Voltage input impedance:20kΩ; 3.AI3 reference potential can be GND or -10V.
Digital input	DI1	Multi-function digital input 1	1.Optocoupler, compatible bipolar input, determined by the choice of the jumper PLC; 2.Input impedance: 3.3kΩ 3.Level input voltage range is 19.2~28.8V. Note: DI5 input impedance is 1.65k.
	DI2	Multi-function digital input 2	
	DI3	Multi-function digital input 3	
	DI4	Multi-function digital input 4	
	DI5	Multi-function digital input 5	
	DI6	Multi-function digital input 6	
	DI7	Multi-function digital input 7	
	DI8	Multi-function digital input 8	
		DI5	High-speed pulse input terminals
Analog output	DA1-GND	Analog output 1	The selected DA1 jumper on control panel determines voltage or current output. Output voltage range: 0~10V , output current range: 0~20mA
	DA2-GND	Analog output 2	The selected DA2 jumper on control panel determines voltage or current output. Output voltage range: 0~10V , output current range: 0~20mA
Digital output	SPA-COM	Digital output 1	Opto-coupler isolation, bipolar open collector output Output voltage range: 0~24V , output current range: 0~50mA
	SPB-COM	Digital output 2	
		SPB-COM	High-speed pulse output
Relay	TA1-	Normally open	Contact drive capacity: Normally closed contact

Category	Symbol	Name	Function
output	TC1	terminals	3A/AC 250V, normally open contact 5 A/AC 250V, COS ϕ = 0.4.
	TB1-TC1	Normally closed terminals	
Motor temperature inspection input	S1-S2-GND	PT100 inspect wire input	PT100 temperature senso. Note: Such as PT100 three detection line, with a universal table test, to find two of the detection line is 0 Ω after the one received S2 terminal, the other received a GND; the remaining one received S1 terminal.
Built-in RS485	485+	485 differential signal + terminal	485 communication interface, 485 differential signal terminal, use twisted-pair or shielded wire connect to the standard 485 communication interface 485 jump line in the control panel to decide whether to connect the terminal resistance
	485-	485 differential signal - terminal	
Auxiliary interface	J13	communication interface	CAN card, 26-pin terminal
	J10	PG card interface	12-pin terminal
	GND	GND ground interface	GND jump line decide whether to connect PE, improve the inverter anti-interference
	COM	COM ground interface	COM jump line decide whether to connect PE, improve the inverter anti-interference
	H1	COM Terminal interface	Consistent with the COM function on the terminal line.

4-4-3. Signal input terminal circuit

Switch input and output signal transmission, generally use the shielded cable and wiring short distance as far as possible, good grounding and shielding layer on the inverter side, try not to over 20 m transmission distance. Drive in active way, elected to the power of crosstalk necessary filtering measures are taken, generally recommend that choose dry contact control mode.

Wiring control cable should be kept with the main circuit and high voltage lines (Such as the power cord, motor connecting line, relay or contactor) more than 20 cm distance, and to avoid high voltage lines parallel to and can't be avoided and the high voltage lines cross, the proposal USES vertical wiring way, in order to prevent the misoperation caused by disturbance frequency converter

Dry contact mode:

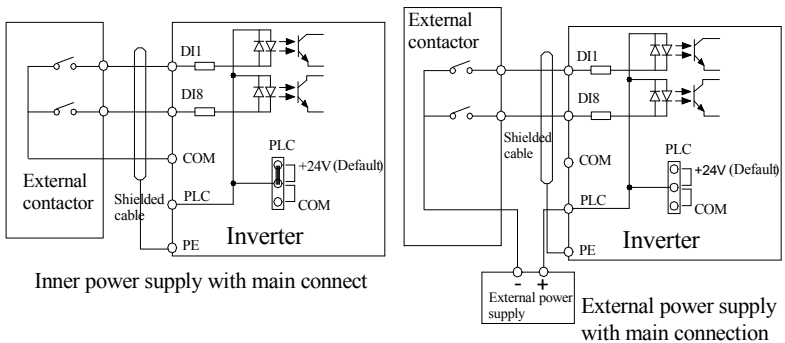
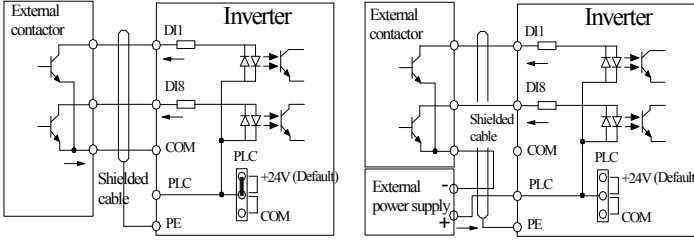

Figure 4-19: Signal input terminal circuit- dry contact mode

Note: using an external power supply, PLC and 24 v jumper cap must be removed, otherwise it will damage the product.

Open collector NPN connect wire:

When the input signal from the NPN transistor, according to the use of power supply, please according to the figure + 24 v and PLC jumper cap.



Inner power NPN connect mode

External power supply NPN connect mode

Figure 4-20: Signal input terminal wiring diagram, open collector NPN connection mode

Note: using an external power supply, PLC and 24 v jumper cap must be removed, otherwise it will damage the product.

Open collector PNP connection mode:

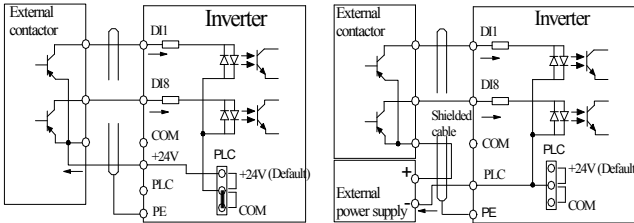

Inner power PNP connect mode

External power supply PNP connect mode

Figure 4-21: Signal input terminal wiring diagram, open collector PNP connection mode

Note: using an external power supply, PLC and 24 v jumper cap must be removed, otherwise it will damage the product.

4-5.Wiring Precautions

⚠ Danger
<p>Make sure that the power switch is in the OFF state before wiring operation, or electrical shock may occur!</p> <p>Wiring must be performed by a professional trained personnel, or this may cause damage to the equipment and personal injury!</p> <p>Must be grounded firmly, otherwise there is a danger of electric shock or fire hazard !</p>
⚠ Note
<p>Make sure that the input power is consistent with the rated value of inverter, otherwise which may cause damage to the inverter!</p> <p>Make sure that the motor matches the inverter, otherwise which may cause damage to the motor or activate the inverter protection!</p>

Do not connect power supply to U, V, W terminals, otherwise which may cause damage to the inverter!

Do not directly connect braking resistor to DC bus (P), (+) terminals, otherwise which may cause a fire!

※The U,V,W output end of inverter can not install phase advancing capacitor or RC absorbing device. The inverter input power must be cut off when replacing the motor

※Do not let metal chips or wire ends into inside the inverter when wiring, otherwise which may cause malfunction to the inverter.

※Disconnect motor or switch power-frequency power supply only when the inverter stops output

※In order to minimize the effects of electromagnetic interference, it is recommended that a surge absorption device shall be installed additionally when electromagnetic contactor and relay is closer from the inverter.

※External control lines of inverter shall adopt isolation device or shielded wire.

※In addition to shielding, the wiring of input command signal should also be aligned separately, it is best to stay away from the main circuit wiring.

※If the carrier frequency is less than 3KHz, the maximum distance between the inverter and the motor should be within 50 meters; if the carrier frequency is greater than 4KHz, the distance should be reduced appropriately, it is best to lay the wiring inside metal tube.

※When the inverter is additionally equipped with peripherals (Filter, reactor, etc.), firstly measure its insulation resistance to ground by using 1000 volt megger, so as to ensure the measured value is no less than 4 megohms.

※When the inverter need to be started frequently, do not directly turn power off, only the control terminal or keyboard or RS485 operation command can be used to control the start/stop operation, in order to avoid damage to the rectifier bridge.

※To prevent the occurrence of an accident, the ground terminal(\perp) must be earthed firmly(Grounding impedance should be less than 10 ohms), otherwise the leakage current will occur.

※The specifications on wires used by the main circuit wiring shall comply with the relevant provisions of the National Electrical Code.

※The motor's capacity should be equal to or less than the inverter's capacity.

4-6.Spare Circuit

When the inverter occurs the fault or trip, which will cause a larger loss of downtime or other unexpected faults. In order to avoid this case from happening, please additionally install spare circuit to ensure safety.

Note: Electrical diagram MCC1 and MCC2 interlock ac contactor; Spare circuit must be confirmed in advance and test running characteristics, make sure that the power frequency and frequency conversion phase sequence

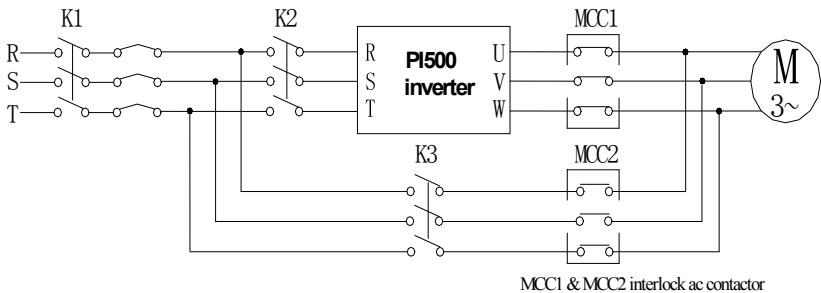

Figure 4-22: Spare Circuit electrical diagram

4-7.Commissioning

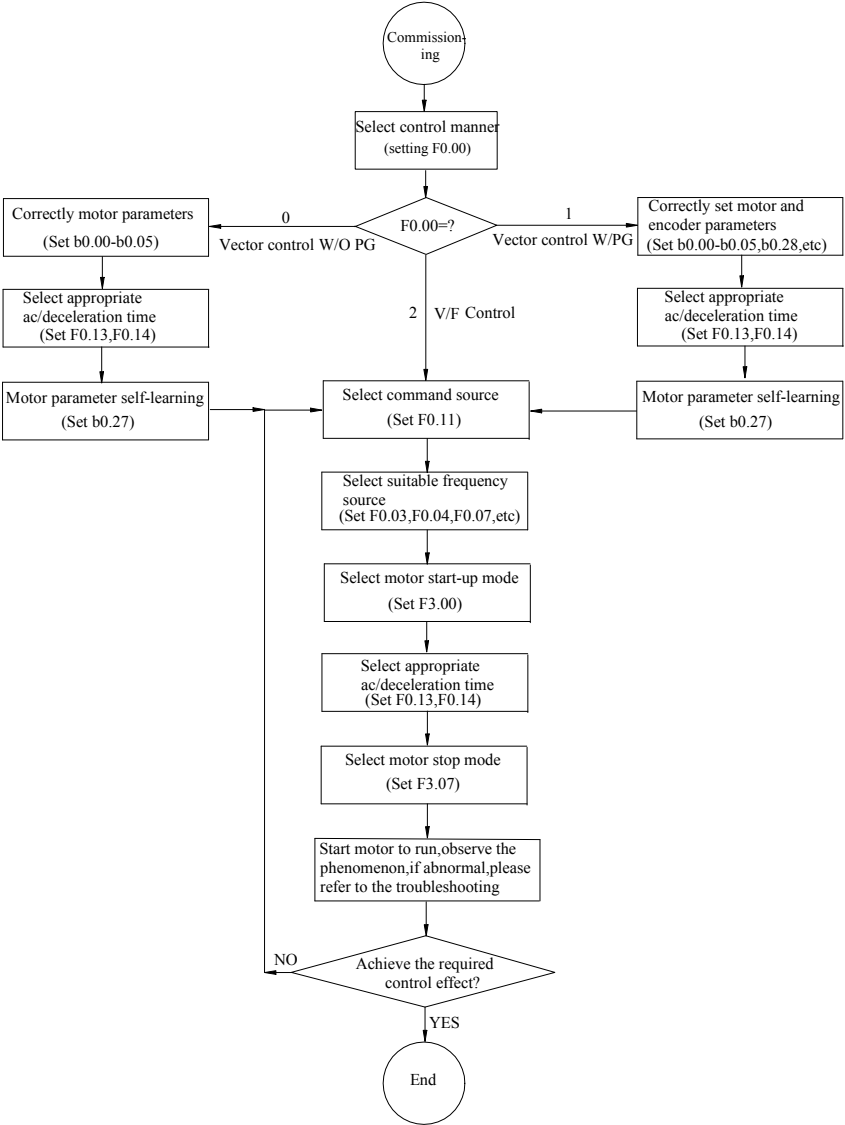

Figure 4-23: Commissioning

- Firstly confirm that AC input power supply voltage shall be within inverter rated input voltage range before connecting power supply to the inverter.
- Connect power supply to the R, S and T terminals of the inverter.
- Select the appropriate operation control method.

Chapter 5 Function parameter

5-1.Menu grouping

Note:

“★”: In running status, can not modify the parameter setting

“●”: The actual testing data, can not be modified

“☆”: In stop and run statuses, both can be changed;

“▲”: “Factory parameter”, no change about it.

“_” means the factory parameter is related to power or model. Please check the details in the involved parameter introduction.

Note:“Italic ³”means software version is C3.00 and the keyboard just like the above with MCU can do the functions.

Change limit refers to whether the parameters are adjustable.

y0.01 is used for parameters protection password. Parameter menu can be enter into only after inputting the right password in the function parameter mode or user change parameter mode. When the y0.01 set to 0, the password is canceled.

Parameter menu is not protected by password under user customized parameters mode.

F group is the basic function parameters,E group is to enhance function parameters, b group is a function of motor parameters,d group is the monitoring function parameters.

Code	Parameter name	Functional Description
d0	Monitoring function group	Monitoring frequency, current, etc
F0	Basic function group	Frequency setting, control mode, acceleration and deceleration time
F1	Input terminals group	Analog and digital input functions
F2	Output terminals group	Analog and digital output functions
F3	Start and stop control group	Start and stop control parameters
F4	V/F control parameters	V/F control parameters
F5	Vector control parameters	Vector control parameters
F6	Keyboard and display	To set key and display function parameters
F7	Auxiliary function group	To set Jog, jump frequency and other auxiliary function parameters
F8	Fault and protection	To set fault and protection parameters
F9	Communication parameter group	To set MODBUS communication function
FA	Torque control parameters	To set parameters under torque control mode
Fb	Control optimization parameters	To set parameters of optimizing the control performance
FC	Extend parameters group	specialapplicationparameterssetting
E0	Wobblulate, fixed-length and counting	To set Wobblulate, fixed-length and counting function parameters
E1	Multi-stage command, simple PLC	Multi-speed setting, PLC operation
E2	PID function group	To set Built-in PID parameters
E3	Virtual DI, Virtual DO	Virtual I/O parameter setting
b0	Motor parameters	To set motor parameter

y0	Function code management	To set password, parameter initialization and parameter group display
y1	Fault query	Fault message query

5-1-1.d0 Group - Monitoring function group

Code	Parameter name	Setting range	Factory setting
d0.00	Running frequency	Frequency converter theory	0.01Hz
d0.01	Set frequency	Actual set frequency	0.01Hz
d0.02	DC bus voltage	Detected value for DC bus voltage	0.1V
d0.03	output voltage	Actual output voltage	1V
d0.04	output current	Effective value for Actual motor current	0.01A
d0.05	output power	Calculated value for motor output power	0.1kW
d0.06	output torque	Motor output torque percentage	0.1%
d0.07	DI input status	DI input status	-
d0.08	DO output status	DO output status	-
d0.09	AI1 voltage (V)	AI1 input voltage value	0.01V
d0.10	AI2 voltage (V)	AI2 input voltage value	0.01V
d0.11	AI3 voltage (V)	AI3 input voltage value	0.01V
d0.12	Count value	Actual pulse count value in counting function	-
d0.13	Length value	Actual length in fixed length function	-
d0.14	Actual operating speed	Motor actual running speed	-
d0.15	PID setting	Reference value percentage when PID runs	%
d0.16	PID feedback	Feedback value percentage when PID runs	%
d0.17	PLC stage	Stage display when PLC runs	-
d0.18	High-speed pulse input frequency	High-speed pulse input frequency display, unit: 0.01Khz	0.01kHz
d0.19	Feedback speed(Unit:0.1Hz)	Actual output frequency of converter	0.01Hz
d0.20	Remaining run time	Remaining run time display, it is for timing run control	0.1Min
d0.21	Linear speed	Show the line speed of DI5 high speed pulse sampling, according to the actual sample pulse number per minute and E0.07, calculate the line speed value.	1m/Min
d0.22	Current power-on time	Total time of current inverter power-on	Min
d0.23	Current run time	Total time of current inverter run	0.1Min
d0.24	HDI(DI5) impulse frequency	HDI(DI5) High-speed impulse input frequency display, unit: 1Hz	1Hz
d0.25	Communication set value	Frequency, torque or other command values set by communication port	0.01%
d0.26	Encoder feedback speed	PG feedback speed, to an accuracy of 0.01Hz	0.01Hz
d0.27	Master frequency	Frequency set by F0.03 master frequency setting	0.01Hz

	display	source	
d0.28	Auxiliary frequency display	Frequency set by F0.04 auxiliary frequency setting source	0.01Hz
d0.29	Command torque (%)	Observe the set command torque under the torque control mode	0.1%
d0.32	Resolver position	Rotor position when rotary transformer is used as a speed feedback	-
d0.33	ABZ position	Position information calculated from when ABZ incremental feedback encoder is adopted	0
d0.34	Z signal counter	Encoder Z-phase signal count	-
d0.35	Inverter status	Display run, standby and other statuses	-
d0.36	Inverter type	1.G type (Constant torque load type) 2.F type (Fans/pumps load type)	-
d0.37	A11 voltage before correction	Input voltage value before A11 linear correction	0.01V
d0.38	A12 voltage before correction	Input voltage value before A12 linear correction	0.01V
d0.39	A13 voltage before correction	Input voltage value before A13 linear correction	0.01V
d0.40	Reserve		
d0.41	Motor temperature inspection function3	PT100 inspect motor temperature value	0°C

5-1-2.F0 Group -Basic function group

Code	Parameter name	Setting range	Factory setting	Change
F0.00	Motor control manner	0.Vector control W/O PG 1.Vector control W/ PG 2.V/F control	2	★
F0.01	Keyboard set frequency	0.00Hz~ F0.19 (Maximum frequency)	50.00Hz	☆
F0.02	Frequency command resolution	1: 0.1Hz; 2: 0.01Hz	2	★
F0.03	Frequency source master setting	0: Frequency setting by keyboard (F0.01, UP/DOWN can be modified, no memory when power off) 1: Frequency setting by keyboard (F0.01, UP/DOWN can be modified, memory when power off) 2: Analog quantity A11 setting 3: Analog quantity A12 setting 4: Panel potentiometer setting 5: High speed pulse setting 6: Multi-speed running setting 7: Simple PLC program setting 8: PID control setting 9: Remote communication setting 10: Analog quantity A13 setting	1	★

F0.04	Frequency source auxiliary setting	The same as F0.03	0	★
F0.05	Reference object selection for frequency source auxiliary setting	0.Relative to maximum frequency 1.Relative to master frequency source 1 2.Relative to master frequency source 2	0	☆
F0.06	Frequency source auxiliary setting range	0% ~ 150%	100%	☆
F0.07	Frequency source superimposed selection	Units digit: Frequency source selection Tens digit: Arithmetic relationship of master and auxiliary for frequency source	00	☆
F0.08	Frequency source offset frequency when superimposing	0.00Hz ~ F0.19(Maximum frequency)	0.00Hz	☆
F0.09	Shutdown memory selection for digital set frequency	0: W/O memory 1: With memory	1	☆
F0.10	Frequency command UP / DOWN reference when running	0: Running frequency 1: Set frequency	0	★
F0.11	Command source selection	0.Keyboard control (LED off) 1.Terminal block control (LED on) 2.Communications command control (LED flashes) 3. Keyboard control+ Communications command control 4. Keyboard control+ Communications command control+ Terminal block control	0	☆
F0.12	Binding frequency source for command source	Units digit: binding frequency source selection for operation panel command 0: No binding; 1. Keyboard setting frequency; 2: Analog quantity AI1 setting 3: Analog quantity AI2 setting 4: Panel encoder setting 5: High speed pulse setting 6: Multi-speed setting 7: Simple PLC setting 8: PID setting 9: Communication given Tens digit: Terminal command binding frequency source selection (0 ~ 9, same as units digit) Hundreds digit: Communication command binding frequency source selection (0 ~ 9, same as units digit)	000	☆
F0.13	Acceleration time 1	0.00s ~ 6500s	Depends on models	☆
F0.14	Deceleration time 1	0.00s ~ 6500s	Depends on models	☆

F0.15	Ac/Deceleration time unit	0:1 second; 1:0.1 second; 2:0.01 second	1	★
F0.16	Ac/deceleration time reference frequency	0: F0.19(Maximum frequency) 1: Set frequency 2: 100Hz	0	★
F0.17	Carrier frequency adjustment as per temperature	0: NO; 1: YES	0	☆
F0.18	Carrier Frequency	0.5kHz ~ 16.0kHz	Depends on models	☆
F0.19	Maximum output frequency	50.00Hz ~ 320.00Hz	50.00Hz	★
F0.20	Upper limit frequency source	0: F0.21 setting 1: AI1 analog quantity setting 2: AI2 analog quantity setting 3: Panel encoder setting 4: High-speed pulse setting 5: Communications reference 6: AI3 analog quantity setting	0	★
F0.21	Upper limit frequency	F0.23 (Lower limit frequency) ~ F0.19(Maximum frequency)	50.00Hz	☆
F0.22	Upper limit frequency offset	0.00Hz ~ F0.19 (Maximum frequency)	0.00Hz	☆
F0.23	Lower limit frequency	0.00Hz ~ F0.21 (Upper limit frequency)	0.00Hz	☆
F0.24	Running direction	0: Same direction; 1: Opposite direction	0	☆
F0.25	Reserve			
F0.26	AI Simulation accuracy	0: 0.01Hz; 1: 0.05Hz; 2: 0.1Hz; 3: 0.5Hz	1	☆
F0.27	GF type	1.G type (Constant torque load type) 2.F type (Fans/pumps load type)	-	●

5-1-3.F1 Group - Input terminals group

Code	Parameter name	Setting range	Factory setting	Change	
F1.00	DI1 terminal function selection	0 ~ 51	1	★	
F1.01	DI2 terminal function selection		2	★	
F1.02	DI3 terminal function selection		8	★	
F1.03	DI4 terminal function selection		9	★	
F1.04	DI5 terminal function selection		12	★	
F1.05	DI6 terminal function selection		13	★	
F1.06	DI7 terminal function selection		0	★	
F1.07	DI8 terminal function selection		0	★	
F1.08	Undefined				
F1.09	Undefined				

The function of digital multifunction input terminal DI1-DI8 (DI5 can be used as a high-speed pulse input terminal), can be set by parameter F1.00-F1.07, and the optional function is shown in the following table:

Setting value	Function	Description
0	No function	The terminal for not use can be set to "no function" to prevent accidental operation.
1	Forward run (FWD)	External terminals are used to control the FWD/REV run mode of inverter.
2	Reverse run (REV)	
3	Three-wire operation control	This terminal is used to determine the inverter's three-wire control mode. For details, please refer to the instructions of function code F1.10 ("Terminal command mode).
4	Forward JOG(FJOG)	FJOG means Forward JOG running, RJOG means Reverse JOG running. For Jog running frequency and Jog Ac/deceleration time, please refer to the description of the function code F7.00, F7.01, F7.02.
5	Reverse JOG(RJOG)	
6	Terminal UP	Modify frequency increment/decrement command when the frequency is referenced by external terminal. Adjust up/down the set frequency when the digital setting is selected as the frequency source.
7	Terminal DOWN	
8	Free stop	The inverter output is blocked, at the time, the parking process of motor is not controlled by the inverter. This way is same as the principle of free stop described in F3.07.
9	Fault reset (RESET)	The function make use of terminal for fault reset. It has same function with RESET key on the keyboard. This function can be used to realize remote fault reset.
10	Run pausing	The inverter slows down and stops, but all operating parameters are memorized. Such as PLC parameters, wobble frequency parameters, and PID parameters. This terminal signal disappears, the inverter reverts to the previous state of running before parking.
11	External fault normally open input	When the signal is sent to the inverter, the inverter reports fault Err.15, and performs troubleshooting according to fault protection action (For details, please refer to the function code F8.17).
12	Multi-speed terminal 1	The setting of 16 stage speed or 16 kinds of other command can be achieved through the 16 states of the four terminals. For details, see Table 1
13	Multi-speed terminal 2	
14	Multi-speed terminal 3	
15	Multi-speed terminal 4	
16	Ac/deceleration time selection terminal 1	The selection of 4 ac/deceleration times can be achieved through the 4 states of the two terminals. For details, see Table 2
17	Ac/deceleration time selection terminal 2	
18	Frequency source switching	Used to switch between different frequency sources. According to frequency source selection function code (F0.07) settings, the terminal is used to switch between two frequency sources.
19	UP/DOWN setting (Terminal, keyboard)	When the frequency reference is the digital frequency, this terminal is used to clear the changed frequency value by terminal UP/DOWN or keyboard UP/DOWN, so that the reference frequency can recover to the set value of F0.01.

20	Run command switch terminal 1	When the command source is set to the terminal control (F0.11 = 1), the terminal can be used to switch between terminal control and keyboard control. When the command source is set to the communication control (F0.11 = 2), the terminal can be used to switch between communication control and keyboard control.
21	Ac/deceleration prohibited	Ensure the inverter is free from external signals affect (Except for shutdown command), maintain current output frequency.
22	PID pause	PID is temporarily disabled, the inverter maintains current output frequency, no longer performs PID adjustment of frequency source.
23	PLC status reset	When PLC pauses and runs again, this terminal is used to reset the inverter to the initial state of simple PLC.
24	Wobble pause	When the inverter outputs at center frequency. Wobble will pause
25	Counter input	Input terminal of the count pulse
26	Counter reset	Clear counter status
27	Length count input	Input terminal of the length count.
28	Length reset	Clear length
29	Torque control prohibited	When the inverter torque control is prohibited, the inverter will enter speed control mode.
30	High-speed pulse input (Only valid for DI5)	DI5 is used as pulse input terminal.
31	Reserve	Reserve
32	Immediately DC braking	If the terminal is active, the inverter switches directly to DC braking status
33	External fault normally closed input	When the signal of external fault normally closed input is inputted into the inverter, the inverter will report fault Err.15 and shutdown.
34	Frequency change enable	If the function is set to be valid, when the frequency changes, the inverter does not respond to frequency changes until the terminal state is invalid.
35	PID action direction as reverse	If the terminal is valid, PID action direction opposites to the direction set by E2.03
36	External parking terminal 1	Under keyboard control mode, the terminal can be used to stop the inverter, same as STOP key on the keyboard.
37	Control command switch terminal 2	Used to switch between terminal control and communication control. If the command source is selected as terminal control, the system will be switched to the communication control mode when the terminal is active; vice versa.
38	PID integral pause	When the terminal is active, the PID integral adjustment function is paused, but the proportion and differential adjustments of PID are still valid.
39	Switch between frequency source master setting and preset frequency	When the terminal is active, the frequency source A is replaced by the preset frequency (F0.01)
40	Switch between frequency source auxiliary setting and	When the terminal is active, the frequency source B is replaced with the preset frequency (F0.01)

	preset frequency	
41	Reserve	
42	Reserve	
43	PID parameter switching	When DI terminal (E2.19 = 1) is used to switch PID parameters, if the terminal is invalid, PID parameters use E2.13~ E2.15; if the terminal is valid, PID parameters use E2.16 ~ E2.18
44	Custom fault 1	When custom fault 1 and custom fault 2 are active, the inverter respectively alarms fault Err.27 and fault Err.28, and deals with them according to the mode selected by the fault protection action F8.19.
45	Custom fault 2	
46	Speed control / torque control switching	Switch between speed control mode and torque control mode under vector control mode. If the terminal is invalid, the inverter will run at the mode defined by FA.00 (Speed/torque control mode); if the terminal is valid, the inverter will be switched to another mode.
47	Emergency parking	If the terminal is valid, the inverter will park at the fastest speed, and the current maintains at the set upper limit during the parking process. This function is used to meet the requirements that the inverter needs to stop as soon as possible when the system is in a emergency state.
48	External parking terminal 2	In any control mode (Keyboard control, terminal control, communication control), the terminal can be used to decelerate the inverter until stop, at the time the deceleration time is fixed for deceleration time 4.
49	Deceleration DC braking	If the terminal is valid, firstly the inverter decelerates to the initial frequency of stop DC braking, and then switches directly to DC braking status.
50	Clear current running time	If the terminal is valid, the inverter's current running time is cleared
51	Jog order	Jog running order,direction set through F7.54

F1.10	Terminal command mode	0: Two-wire type 1; 1: Two-wire type 2 2: Three-wire type 1; 3: Three-wire type 2	0	★
F1.11	Terminal UP/DOWN change rate	0.001Hz/s ~65.535Hz/s	1.000Hz/s	☆
F1.12	Minimum input for AIC1	0.00V ~F1.14	0.30V	☆
F1.13	F1.12corresponding setting	-100.0% ~+100.0%	0.0%	☆
F1.14	Maximum input for AIC1	F1.12 ~+10.00V	10.00V	☆
F1.15	F1.14corresponding setting	-100.0% ~+100.0%	100.0%	☆
F1.16	Minimum input for AIC2	0.00V ~F1.18	0.00V	☆
F1.17	F1.16corresponding setting	-100.0% ~+100.0%	0.0%	☆
F1.18	Maximum input for AIC2	F1.16 ~+10.00V	10.00V	☆
F1.19	F1.18corresponding setting	-100.0% ~+100.0%	100.0%	☆
F1.20	Minimum input for AIC3	-10.00V ~F1.22	0.00V	☆

F1.21	F1.20corresponding setting	-100.0% ~+100.0%	0.0%	☆
F1.22	Maximum input for AIC 3	F1.20 ~+10.00V	10.00V	☆
F1.23	F1.22corresponding setting	-100.0% ~+100.0%	100.0%	☆
F1.24	AIcurve selection	Units digit: AI1 curve selection Tens digit: AI2 curve selection Hundreds digit:panel potentiometer curve selection	321	☆
F1.25	Setting selection for AI input	Units digit: Setting selection for AI1 less than minimum input 0: Corresponding to minimum setting 1: 0.0% Tens digit: Setting selection for AI2 less than minimum input, ditto Hundreds digit: Setting selection for AI3 less than minimum input(0 ~ 1,ditto)	000	☆
F1.26	HDI Minimum pulse input	0.00kHz~F1.28	0.00kHz	☆
F1.27	F1.26 corresponding setting	-100.0%~+100.0%	0.0%	☆
F1.28	HDI Maximum input	F1.26~100.00kHz	50.00kHz	☆
F1.29	F1.28 corresponding setting	-100.0%~+100.0%	100.0%	☆
F1.30	DI filter time	0.000s~1.000s	0.010s	☆
F1.31	AI1 filter time	0.00s~10.00s	0.10s	☆
F1.32	AI2 filter time	0.00s~10.00s	0.10s	☆
F1.33	AI3 filter time	0.00s~10.00s	0.10s	☆
F1.34	HDI Filter time	0.00s~10.00s	0.00s	☆
F1.35	DI terminal valid mode selection 1	Units digit: DI1 0: High level active; 1: Low level active Tens digit: DI2 Hundreds digit: DI3 Thousands digit: DI4 Ten thousands digit: DI5	00000	★
F1.36	DI terminal valid mode selection 2	Units digit: DI6 0: High level active; 1: Low level active Tens digit: DI7 Hundreds digit: DI8 Thousands digit: DI9 Ten thousands digit: DI10	00000	★
F1.37	DI1 delay time	0.0s~3600.0s	0.0s	★
F1.38	DI2 delay time	0.0s~3600.0s	0.0s	★
F1.39	DI3 delay time	0.0s~3600.0s	0.0s	★
F1.40	Define the input terminal repeat	0:Unrepeatable 1:repeatable	0	★
F1.41	Keyboard Encoder X1	0~100.00%	0.00%	☆

F1.42	Keyboard Encoder X2	0~100.00%	0.50%	☆
F1.43	Keyboard Encoder set value	0~100.00%	-	☆
F1.44	Keyboard Encoder X1 corresponding value Y1	-100.00%~+100.00%	0.00%	☆
F1.45	Keyboard Encoder X2 corresponding value Y2	-100.00%~+100.00%	100.00%	☆
F1.46	Keyboard Encoder control	Bits: 0: Power down protection; 1: Power down zero clear Ten bits: 0: Stop keep; 1: Stop order zero clear 2: Stop over zero clear Hundred bits: Reserve Thousand bits: Reserve	00	☆

5-1-4.F2 Group - Output terminals group

Code	Parameter name	Setting range	Factory setting	Change
F2.00	SPB terminal output mode selection	0~ 1	0	☆
F2.01	Switching quantity output function selection	0~ 40	0	☆
F2.02	Relay 1 output function selection (TA1.TB1.TC1)		2	☆
F2.03	Undefined			
F2.04	SPA output function selection (Collector open circuit output terminals)		1	☆
F2.05	Relay 2 output function selection (TA2.TC2)		1	☆

Above 5 function code is used to select five digital output function. Multifunctional output terminal functions are as follows:

Setting value	Functions	Description
0	No output	No output action
1	Inverter running	Inverter is in running state, the output frequency (Can be zero), the output ON signal.
2	Fault output (Fault down)	When the drive fails and downtime, the output ON signal.
3	Frequency level detection FDT1 output	Please refer to the function code F7.23, F7.24's instructions.
4	Frequency arrival	Please refer to the description of function code F7.25.
5	Zero-speed running (No output when shutdown)	Inverter operation and the output frequency is 0, output ON signal. When the drive is shut down, the signal is OFF.
6	Motor overload pre-alarm	Before the motor overload protection, according to the overload pre-alarm threshold value judgment, more than the pre-alarm threshold value output ON signal. Motor overload parameter settings refer to the function code F8.02 ~ F8.04.
7	Inverter overload pre-alarm	Before the inverter overload occurs 10s, output ON signal. Setup counter arrive
8	Setup counter arrive	When the count reaches the set value of E0.08, output ON signal. Specifies the count value reaches

9	Specifies the count value reaches	When the count reaches the set value of E0.09, output ON signal. Counting Function Reference E0 group
10	Length arrival	When the actual length of the detection of more than E0.05 set length, output ON signal.
11	PLC cycle is complete	After simple PLC completes one cycle, the output of a pulse width of 250ms signal.
12	Total running time arrival	Inverter total running time of more than F7.21 F6.07 set time, the output ON signal.
13	Limited in frequency	When the set frequency exceeds the upper limit frequency or lower frequency, and output frequency is beyond the upper limit frequency or lower limit frequency, output ON signal.
14	Torque limiting	Drive under the speed control mode, when the output torque reaches the torque limit, the inverter is stall protection status, while the output ON signal.
15	Ready to run	When the inverter main circuit and control circuit power supply has stabilized, and the drive does not detect any fault information, the drive is in an operational state, output ON signal.
16	AI1>AI2	When the value of the analog input AI1 is greater than the value of AI2 input and output ON signal.
17	Upper frequency arrival	When the operating frequency reaches the upper frequency, output ON signal.
18	The lower frequency arrival (No output when shutdown)	When the operating frequency reaches the lower frequency, output ON signal. The next stop status signal is OFF.
19	Under voltage state output	When the inverter is in an undervoltage condition, output ON signal.
20	Communication setting	Refer to the communication protocol.
21	Reserve	Reserve
22	Reserve	Reserve
23	Zero-speed operation 2 (Shutdown also output)	The inverter's output frequency is 0, output ON signal. The signal is also ON when shutdown.
24	Cumulative power-on time arrival	When the inverter's accumulated power on time (F6.08) over F7.20 the set time, the output ON signal.
25	Frequency level detection FDT2 output	Please refer to the function code F7.26, F7.27's instructions.
26	Frequency 1 reaches output	Please refer to the function code F7.28, F7.29's instructions.
27	Frequency 2 reaches output	Please refer to the function code F7.30, F7.31's instructions.
28	Current 1 reaches output	Please refer to the function code F7.36, F7.37's instructions.
29	Current 2 reaches output	Please refer to the function code F7.38, F7.39's instructions.
30	Timing reach output	When the timer function selection (F7.42) is valid, the drive time to reach this run after the set time runs out, output ON signal.
31	AI1 input overrun	When the value of analog input AI1 greater than F7.51 (AI1 input protection limit) or less than F7.50 (AI1 input protection under), output ON signal.
32	Off load	When the inverter is off-load state, output ON signal.

33	Reverse operation	Inverter in reverse run, output ON signal		
34	0 current state	Refer to the description of function code F7.32, F7.33.		
35	Module temperature reaches	Inverter module heatsink temperature (F6.06) reach the set module temperature reaches value (F7.40), output signal ON.		
36	Software current limit	Please refer to the function code F7.34, F7.35's instructions.		
37	The lower frequency arrival (Stop and output)	When the operating frequency reaches the lower limit frequency, output ON signal. In shutdown state of the signal is also ON.		
38	Alarm output	When the inverter failure, and the failure of the process to continue to run mode, the inverter alarm output.		
39	Motor overtemperature pre-warning	When the motor temperature reaches F8.35 (Motor overheat pre-alarm threshold), the output ON signal. (Motor temperature can be viewed at d0.41)		
40	Current running time of arrival	When the inverter starts running time is longer than the time set by F7.45, it outputs ON signal.		
F2.06	High-speed pulse output function selection	0~17	0	☆
F2.07	DA1 output function selection		2	☆
F2.08	DA2 output function selection		13	☆
<p>High-speed pulse output frequency range of 0.01kHz ~ F2.09 (High speed pulse output maximum frequency), F2.09 can be set between 0.01kHz ~ 100.00kHz.</p> <p>Analog Output DA1 and DA2 output range is 0V ~ 10V, or 0mA ~ 20mA. Pulse output or analog output range, with the corresponding scaling function relationship in the following table:</p>				
Setting value	Functions	Description		
0	Running frequency	0~Max. output frequency		
1	Set frequency	0~ Max. output frequency		
2	Output current	0~2 times the motor rated current		
3	Output torque	0~2 times the motor rated toqure		
4	Output power	0~2 times rated power		
5	Output voltage	0~1.2 times inverter rated voltage		
6	High speed pulse input	0.01kHz~100.00kHz		
7	Anolog AI1	0V~10V(/ 0~20mA)		
8	Anolog AI2	0V~10V(/ 0~20mA)		
9	Anolog AI3	0V~10V		
10	Lentgh value	0~Max. setting length		
11	The count value	0~Max. count value		
12	Coummunication set	0.0%~100.0%		
13	Motor speed	0~Max. output frequency correspondent speed		
14	Output current	0.0A~100.0A(Inverter power \leq 55kW); 0.0A~1000.0A(Inverter power>55kW)		
15	DC bus voltage	0.0V~1000.0V		
16	Reserve	Reserve		
17	Frequency source main set	0~Max. output frequency		
F2.09	Maximum output frequency of high-speed pulse	0.01kHz~100.00kHz	50.00kHz	☆

F2.10	SPB switching quantity output delay time	0.0s~3600.0s	0.0s	☆
F2.11	Relay 1 output delay time	0.0s~3600.0s	0.0s	☆
F2.12	Expansion card DO output delay time	0.0s~3600.0s	0.0s	☆
F2.13	SPA output delay time	0.0s~3600.0s	0.0s	☆
F2.14	Relay 2 output delay time	0.0s~3600.0s	0.0s	☆
F2.15	DO output terminal active status selection	Units digit: SPB switching quantity 0: Positive logic; 1: Anti-logic Tens digit: Relay 1 Hundreds digit: Hundreds digit: Undefined Thousands digit: SPA Ten thousands digit: Relay 2	00000	☆
F2.16	DA1 zero bias coefficient	-100.0% ~ +100.0%	0.0%	☆
F2.17	DA1 gain	-10.00 ~ +10.00	1.00	☆
F2.18	DA2 zero bias coefficient	-100.0% ~ +100.0%	20.0%	☆
F2.19	DA2 gain	-10.00 ~ +10.00	0.80	☆

5-1-5.F3 Group - Start and stop control group

Code	Parameter name	Setting range	Factory setting	Change
F3.00	Start-up mode	0: Direct startup 1: Speed tracking restart 2: Pre-excitation start (AC asynchronous motor)	0	☆
F3.01	Speed tracking mode	0~2: Reserve 3: Rotate speed tracking method3	3	★
F3.02	Speed tracking value	1~100	20	☆
F3.03	Start frequency	0.00Hz~10.00Hz	0.00Hz	☆
F3.04	Hold time for start frequency	0.0s~100.0s	0.0s	★
F3.05	DC beforehand field current	0%~100%	0%	★
F3.06	DC excitation time beforehand	0.0s~100.0s	0.0s	★
F3.07	Stop mode	0: Deceleration parking 1: Free stop	0	☆
F3.08	DC Initial frequency	0.00Hz~F0.19 (Maximum frequency)	0.00Hz	☆
F3.09	DC Waiting time	0.0s~100.0s	0.0s	☆
F3.10	Stop DC braking current	0%~100%	0%	☆
F3.11	Stop DC braking time	0.0s~100.0s	0.0s	☆
F3.12	Braking utilization rate	0%~100%	100%	☆
F3.13	Ac/deceleration mode	0: Linear acceleration and deceleration 1:S curve acceleration and deceleration A 2:S curve acceleration and deceleration B	0	★

F3.14	Proportion of S curve start-section	0.0%~(100.0%to F3.15)	30.0%	★
F3.15	Proportion of S curve end-section	0.0%~(100.0%~F3.14)	30.0%	★

5-1-6.F4 Group - V/F control parameters

Code	Parameter name	Setting range	Factory setting	Change
F4.00	V/F curve setting	0: Linear V/F,Suitable for ordinary constant torque load. 1: Multi-point V/F,Suitable for dehydrator, centrifuge and other special loads any V/F relationship curves can be obtained by setting parameters F4.03~F4.08. 2: Square V/F,Suitable for fans, pumps and centrifugal loads. 3~8: V/F relationship curve between linear V/F and square V/F.	0	★
F4.01	Torque boost	0.0%(Automatic torque boost) 0.1~30%	0.0%	★
F4.02	Torque boost cut-off frequency	0.00Hz~F0.19(Maximum frequency)	15.00Hz	★
F4.03	MultipointV/F frequency point 1	0.00Hz~F4.05	-	★
F4.04	Multipoint V/F voltage point 1	0.0%~100.0%	-	★
F4.05	Multipoint V/F frequency point 2	F4.03~F4.07	-	★
F4.06	Multipoint V/F voltage point 2	0.0%~100.0%	-	★
F4.07	Multipoint V/F frequency point 3	F4.05~b0.04 (Rated motor frequency)	-	★
F4.08	Multipoint V/F voltage point 3	0.0%~100.0%	-	★
F4.09	Slip compensation coefficient	0%~200.0%	0.0%	☆
F4.10	Overexcitation gain	0~200	80	☆
F4.11	Oscillation suppression gain	0~100	0	☆
F4.12	V/F separation voltage source	0~9	0	☆
F4.13	V/F separation voltage digital setting	0V~rated motor voltage	0V	☆
F4.14	V/F separation voltage rise time	0.0s~1000.0s	0.0s	☆
F4.15	V / F automatic torque lifting KP	0~100	56	☆
F4.16	V / F automatic torque lifting ki	0~100	49	☆
F4.17	V / F automatic torque raising Max	0~2000	1228	☆
F4.18	V / F automatic torque raising min	0: Determined by power; 1: Changed manually	0	☆
F4.19	V / F automatic torque lifting adjustment	0~200%	100%	☆
F4.20	AVR automatic voltage	0: Enable;	0	☆

regulation	1: Not enable		
------------	---------------	--	--

5-1-7.F5 Group - Vector control parameters

Code	Parameter name	Setting range	Factory setting	Change
F5.00	Speed loop ratio G1	1~100	30	☆
F5.01	Speed loop integral T1	0.01s~10.00s	0.50s	☆
F5.02	switching frequency 1	0.00~F5.05	5.00Hz	☆
F5.03	Speed loop ratio G2	0~100	20	☆
F5.04	Speed loop integral T2	0.01s~10.00s	1.00s	☆
F5.05	Switching frequency 2	F5.02~F0.19(Max. Frequency)	10.00Hz	☆
F5.06	Speed loop integral	0: Invalid 1: Valid	0	☆
F5.07	Torque limit upper limit source	0: Function code F5.08 setting 1: AI1 2: AI2 3: Panel potentiometer setting 4: High-speed pulse setting 5: Communication setting 6: Min(AI1, AI2) 7: Max(AI1, AI2) 8: AI3 setting	0	☆
F5.08	Upper limit digital setting for torque	0.0%~200.0%	150.0%	☆
F5.09	Vector control differential gain	50%~200%	150%	☆
F5.10	Speed loop filter time constant	0.000s~0.100s	0.000s	☆
F5.11	Vector control overexcitation gain	0~200	64	☆
F5.12	Excitation regulator proportional gain	0~60000	2000	☆
F5.13	Excitation regulator integral gain	0~60000	1300	☆
F5.14	Torque regulator proportional gain	0~60000	2000	☆
F5.15	Torque regulator integral gain	0~60000	1300	☆

5-1-8.F6 Group - Keyboard and display

Code	Parameter name	Setting range	Factory setting	Change
F6.00	STOP/RESET key functions	0: STOP/RES key is enabled only under keyboard operation mode 1: STOP/RES key is enabled under any operation mode	1	☆
F6.01	Running status display parameters 1	0x0000~0xFFFF	001F	☆
F6.02	Running status display parameters 2	0x0000~0xFFFF	0000	☆
F6.03	Stop status display parameters	0x0000~0xFFFF	0033	☆

F6.04	Load speed display coefficient	0.0001~6.5000		3.0000	☆
F6.05	Decimal places for load speed display	0:0 decimal places 2:2 decimal places 1:1 decimal places 3:3 decimal places		1	☆
F6.06	Inverter module radiator temperature	0.0℃~100.0℃		-	●
F6.07	Total run time	0h~65535h		-	●
F6.08	Total power-on time	0h~65535h		-	●
F6.09	Total power consumption	0~65535 kwh		-	●
F6.10	Product series number	Frequency inverter series number		-	●
F6.11	Software version number	Control board software version		-	●
F6.13	Communication read-write data selection	Bit: CRC error response selection 0: CRC error response selection; 1: CRC error response selection Ten: broadcast message screening option 0: No shielding; 1: Shielding. 100 bits: Frequency converter fault information read selection 0: Read; 1: Not read.		011	☆
F6.16	Monitor selection 2	1Kbit/100bit	10bit/1bit	d0.04	☆
		Parameter number	Parameter series number		
F6.17	Power correction coefficient	0.00~10.00		1.00	☆
F6.18	Multifunction key definition 1	0: UP key is defined as add function key 1: UP key is defined free stop 2: UP key is defined Forward running 3: UP key is defined Reverse running 4: UP key is defined Forward Jog running 5: UP key is defined Reverse Jog running 6: UP key is defined UP function key 7: UP key is defined DOWN function key		0	☆
F6.19	Multifunction key definition 2	The same as F6.18		0	☆
F6.20	Keypad lock selection	0: RUN, STOP button valid 1: RUN, STOP, keypad encode valid 2: RUN, STOP, UP, DOWN button valid 3: STOP button valid		0	☆
F6.21	QUICK key function selection	0: No function; 1: Jog running 2: Shift switch display state 3: FWD/RVS switchover 4: Clear-up UP/DOWN setting 5: Free stop 6: Running command given in sequence		1	☆

5-1-9.F7 Group - Auxiliary function group

Code	Parameter name	Setting range	Factory setting	Change
F7.00	Jog running frequency	0.00Hz~F0.19(Maximum frequency)	2.00Hz	☆
F7.01	Jog acceleration time	0.0s~6500.0s	20.0s	☆
F7.02	Jog deceleration time	0.0s~6500.0s	20.0s	☆
F7.03	Jog priority	0:Invalid 1: Valid	1	☆
F7.04	Jump frequency 1	0.00Hz~F0.19 (Maximum frequency)	0.00Hz	☆
F7.05	Jump frequency 2	0.00Hz~F0.19(Maximum frequency)	0.00Hz	☆
F7.06	Jump frequency range	0.00Hz~F0.19 (Maximum frequency)	0.00Hz	☆
F7.07	Jump frequency availability during ac/deceleration process	0: Invalid 1: Valid	0	☆
F7.08	Acceleration time 2	0.0s~6500.0s	Depends on models	☆
F7.09	Deceleration time 2	0.0s~6500.0s	Depends on models	☆
F7.10	Acceleration time 3	0.0s~6500.0s	Depends on models	☆
F7.11	Deceleration time 3	0.0s~6500.0s	Depends on models	☆
F7.12	Acceleration time 4	0.0s~6500.0s	Depends on models	☆
F7.13	Deceleration time 4	0.0s~6500.0s	Depends on models	☆
F7.14	Switching frequency point between acceleration time 1 and acceleration time 2	0.00Hz~F0.19 (Maximum frequency)	0.00Hz	☆
F7.15	Switching frequency point between deceleration time 1 and deceleration time 2	0.00Hz~F0.19 (Maximum frequency)	0.00Hz	☆
F7.16	Forward/reverse rotation deadband	0.00s~3600.0s	0.00s	☆
F7.17	Reverse rotation control	0: Enable 1: Disable	0	☆
F7.18	Set frequency lower than lower limit frequency mode	0: Running at lower limit frequency 1: Stop 2: zero speed running	0	☆
F7.19	Droop control	0.00Hz~10.00Hz	0.00Hz	☆
F7.20	Setting cumulative power-on arrival time	0h~36000h	0h	☆
F7.21	Setting cumulative running arrival time	0h~36000h	0h	☆

F7.22	Start protection selection	0: OFF 1: ON	0	☆
F7.23	Frequency detection value (FDT1)	0.00Hz~F0.19(Maximum frequency)	50.00Hz	☆
F7.24	Frequency detection hysteresis value (FDT1)	0.0%~100.0% (FDT1 level)	5.0%	☆
F7.25	Frequency reaches detection width	0.00~100% (Maximum frequency)	0.0%	☆
F7.26	Frequency detection value (FDT2)	0.00Hz~F0.19 (Maximum frequency)	50.00Hz	☆
F7.27	Frequency detection hysteresis value (FDT2)	0.0%~100.0% (FDT2 level)	5.0%	☆
F7.28	Random arrivals frequency detection value 1	0.00Hz~F0.19 (Maximum frequency)	50.00Hz	☆
F7.29	Random arrivals frequency detection width 1	0.00%~100.0% (Maximum frequency)	0.0%	☆
F7.30	Random arrivals frequency detection value 2	0.00Hz~F0.19 (Maximum frequency)	50.00Hz	☆
F7.31	Random arrivals frequency detection width 2	0.00%~100.0% (Maximum frequency)	0.0%	☆
F7.32	Zero current detection level	0.0%~300.0% (Rated motor current)	5.0%	☆
F7.33	Zero current detection delay time	0.01s~360.00s	0.10s	☆
F7.34	Overrun value of output current	0.0% (Not detected) 0.1%~300.0% (Rated motor current)	200.0%	☆
F7.35	Output current overrun detection delay time	0.00s~360.00s	0.00s	☆
F7.36	Random arrivals current 1	0.0%~300.0% (Rated motor current)	-100.0%	☆
F7.37	Random arrivals current 1 width	0.0%~300.0% (Rated motor current)	0.0%	☆
F7.38	Random arrivals current 2	0.0%~300.0% (Rated motor current)	-100.0%	☆
F7.39	Random arrivals current 2 width	0.0%~300.0% (Rated motor current)	0.0%	☆
F7.40	Module temperature arrival	0℃~100℃	75℃	☆
F7.41	Cooling fan control	0: Fan running only when running 1: Fan always running	0	☆
F7.42	Timing function selection	0: Invalid ; 1: Valid	0	★
F7.43	Timing run time selection	0: F7.44 setting 1: A11 2: A12 3: Panel potentiometer Analog input range corresponds~F7.44	0	★
F7.44	Timing run time	0.0Min~6500.0Min	0.0Min	★
F7.45	Current running reaches the set time.	0.0Min~6500.0Min	0.0Min	★

F7.46	Awakens frequency	dormancy frequency(F7.48)to maximum frequency (F0.19)	0.00Hz	☆
F7.47	Awakens delay time	0.0s~6500.0s	0.0s	☆
F7.48	Dormancy frequency	0.00Hz~awakens requency(F7.46)	0.00Hz	☆
F7.49	Dormancy delay time	0.0s~6500.0s	0.0s	☆
F7.50	All input voltage protection lower limit	0.00V~F7.51	3.1V	☆
F7.51	All input voltage protection upper limit	F7.50~10.00V	6.8V	☆
F7.52	Output phase loss protection factor	0~50%	15%	☆
F7.53	Output phase loss detection time multiple	0.0~50.0	1.2	☆
F7.54	Jog mode setting3	Bits: 0: Forward 1: Reverse 2: Determine the direction from the main termina Ten bits: 0: Restore to the previous state after jogging 1: Stop running after jogging Hundred bits: 0:Recover to the previous deceleration time after jogging 1: Keep the deceleration time the sameafter jogging	002	☆

5-1-10.F8 Group - Fault and protection

Code	Parameter name	Setting range	Factory setting	Change
F8.00	Overcurrent stall gain	0~100	20	☆
F8.01	Overcurrent stall protection current	100%~200%	-	☆
F8.02	Motor overload protection selection	0: Invalid 1: Enable	1	☆
F8.03	Motor overload protection gain	0.20~10.00	1.00	☆
F8.04	Motor overload pre-alarm coefficient	50%~100%	80%	☆
F8.05	Over-voltage stall gain	0~100	0	☆
F8.06	Over-voltage stall protection voltage / energy consumption brake voltage	120%~150%	130%	☆
F8.07	Input phase loss protection selection	Units digit:Input phase loss protection selection 0: Invalid 1: Enable Tens digit:contactor actuation	11	☆

		protection 0: Invalid 1: Enable		
F8.08	Output phase loss protection selection	0: Invalid 1: Enable	1	☆
F8.09	Short~ground protection	0:Invalid 1: Valid	1	☆
F8.10	Number of automatic fault reset	0~32767	0	☆
F8.11	Fault DO action selection during automatic fault reset	0: OFF 1: ON	0	☆
F8.12	Automatic fault reset interval	0.1s~100.0s	1.0s	☆
F8.13	Over-speed detection value	0.0~50.0% (Maximum frequency)	20.0%	☆
F8.14	Over-speed detection time	0.0~60.0s	1.0s	☆
F8.15	Detection value for too large speed deviation	0.0~50.0% (Maximum frequency)	20.0%	☆
F8.16	Detection time for too large speed deviation	0.0~60.0s	5.0s	☆
F8.17	Fault protection action selection 1	Units digit: Motor overload (Err.11) 0: Free stop 1: Stop at the selected mode 2: Continue to run Tens digit: input phase loss (Err.12) (Same as units digit) Hundred digit: Output phase loss (Err.13) (Same as units digit) Thousand digit: External fault (Err.15) (Same as units digit) Ten thousands digit: Communication abnormal(Err.16)(Same as units digit)	00000	☆
F8.18	Fault protection action selection 2	Units digit: Encoder fault(Err.20) 0: Free stop 1:Switch to V/F and then stop at the selected mode 2:Switch to V/F and continue to run Tens digit: function code read and write abnormal (Err.21) 0: Free stop 1: Stop at the selected mode Hundreds digit: Reserved Thousands digit: Motor overheating (Err.45) (Same as F8.17 units digit) Ten thousands digit: Running time arrival(Err.26)(Same as F8.17 units digit)	00000	☆
F8.19	Fault protection action selection 3	Units digit:User-defined fault 1(Err.27) (Same as F8.17 units digit) Tens digit:User-defined fault 2(Err.28) (Same as F8.17 units digit) Hundreds digit: Power-on time	00000	☆

		arrival (Err.29) (Same as F8.17 units digit) Thousands digit: Reserved Ten thousands digit: PID feedback loss when running (Err.31) (Same as F8.17 units digit)		
F8.20	Fault protection action selection 4	Units digit: Too large speed deviation (Err.42) (Same as F8.17 units digit) Tens digit: Motor over-speed (Err.43) Hundreds digit: Initial position error (Err.51) (Same as F8.17 units digit) Thousands digit: Reserved Ten thousands digit: Reserved	00000	☆
F8.21~ F8.23	Reserve			
F8.24	Fault running frequency	0: Current frequency running 1: Setting frequency running 2: Upper frequency running 3: Down frequency running 4: Abnormal reserve frequency running	0	☆
F8.25	Abnormal reserve frequency	60.0%~100.0%	90%	☆
F8.26	Momentary power cut action selection	0: Invalid 1: Deceleration 2: Deceleration and stop	0.50s	☆
F8.27	Reserved			
F8.28	Recovery voltage judgment time of momentary power cut	0.00s~100.00s	0	☆
F8.29	Judgment voltage of momentary power cut action	50.0%~100.0% (Standard bus voltage)	10%	☆
F8.30	Load drop protection selection	0: Invalid 1: Valid	1.0s	☆
F8.31	load drop detection level	0.0~100.0%	0	☆
F8.32	Load drop detection time	0.0~60.0s	110	☆
F8.33	Motor temperature sensor type	0: Invalid; 1:PT100 detect	0	☆
F8.34	Motor over heat protection value	0~200	110	☆
F8.35	Motor over heat alma value	0~200	90	☆
F8.36	Start short circuit protection	0: Enable; 1:Not enable	0	☆
F8.37	Holzer detection	0: Two way hall; 1:Three way Hall	0	☆
F8.38	Three way hall operation short circuit to ground threshold	0~100%(Relative motor current)	8%	☆

5-1-11.F9 Group - Communication parameter

Code	Parameter name	Setting range	Factory	Change
------	----------------	---------------	---------	--------

			setting	
F9.00	Baud rate	Units digit:MODBUS Tens digit:Profibus-DP Hundreds digit:Reserve Thousands digit:CAN bus baudrate	6005	☆
F9.01	Data format	0: No parity (8-N-2); 2: Odd parity (8-O-1) 1: Even parity (8-E-1); 3: No parity (8-N-1)	0	☆
F9.02	This unit address	1-250, 0 for broadcast address	1	☆
F9.03	Response delay	0ms-20ms	2ms	☆
F9.04	Communication timeout time	0.0(Invalid); 0.1~60.0s	0.0	☆
F9.05	Data protocol selection	Units digit: MODBUS 0: Non-standard MODBUS protocol 1: Standard MODBUS protocol Tens digit: Profibus-DP 0: PP01 format; 1: PP02 format 2: PP03 format; 3: PP05 format	31	☆
F9.06	Current resolution	0: 0.01A 1: 0.1A	0	☆
F9.07	Baud rate	Units digit:MODBUS Tens digit:Profibus-DP Hundreds digit:Reserve Thousands digit:CAN bus baudrate	6005	☆

5-1-12.FA Group - Torque control parameters

Code	Parameter name	Setting range	Factory setting	Change
FA.00	Speed/torque control mode selection	0: Speed control 1: Torque control	0	★
FA.01	Torque setting source selection under torque control mode	0: Keyboard setting (FA.02) 1: Analog AI1 setting 2: Analog AI2 setting 3: Panel potentiometer setting 4: High-speed pulse setting 5: Communications reference 6: MIN (AI1, AI2) 7: MAX (AI1, AI2) 8: High-speed pulse setting	0	★
FA.02	Torque figures set under torque control mode	-200.0%~200.0%	150%	☆
FA.03	Torque control acceleration time	0.00s~650.00s	0.00s	☆
FA.04	Torque control deceleration time	0.00s~650.00s	0.00s	☆
FA.05	Torque control forward maximum frequency	0.00Hz~F0.19(Maximum frequency)	50.00Hz	☆
FA.06	Torque control backward maximum frequency	0.00Hz~F0.19 (Maximum frequency)	50.00Hz	☆
FA.07	Torque filter time	0.00s~10.00s	0.00s	☆

5-1-13.Fb group - Control optimization parameters

Code	Parameter name	Setting range	Factory setting	Change
Fb.00	Fast current limiting manner	0: Invalid 1: Enable	-	☆
Fb.01	Under-voltage point setting	50.0%~140.0%	100.0%	☆
Fb.02	Over-voltage point setting	200.0V~2500.0V	810V	☆
Fb.03	Deadband compensation mode selection	0: No compensation 1: Compensation mode 1 2: Compensation mode 2	1	☆
Fb.04	Current detection compensation	0~100	5	☆
Fb.05	Vector optimization without PG mode selection	0: No optimization 1: Optimization mode 1 2: Optimization mode 2	1	☆
Fb.06	Upper limiting frequency for DPWM switching	0.00Hz~15.00Hz	12.00Hz	☆
Fb.07	PWM modulation manner	0:Asynchronous; 1:Synchronous	0	☆
Fb.08	Random PWM depth	0: Invalid 1~10: PWM carrier frequency random depth	0	☆
Fb.09	Deadband time adjustment	100%~200%	150%	☆

5-1-14.FC Group - Extended parameter group

Code	Parameter name	Setting range	Factory setting	Change
FC.00	Undefined			
FC.01	Proportional linkage coefficient	0.00~10.00	0	☆
FC.02	PIDstart deviation	0.0~100.0	0	☆

5-1-15.E0 Group - Wobble, fixed-length and counting

Code	Parameter name	Setting range	Factory setting	Change
E0.00	Swing setting manner	0: Relative to center frequency 1: Relative to maximum frequency	0	☆
E0.01	Wobble range	0.0%~100.0%	0.0%	☆
E0.02	Sudden jump frequency range	0.0%~50.0%	0.0%	☆
E0.03	Wobble cycle	0.1s~3000.0s	10.0s	☆
E0.04	Triangle wave rise time coefficient	0.1%~100.0%	50.0%	☆
E0.05	Set length	0m~65535m	1000m	☆
E0.06	Actual length	0m~65535m	0m	☆
E0.07	Pulse per meter	0.1~6553.5	100.0	☆
E0.08	Set count value	1~65535	1000	☆
E0.09	Specified count value	1~65535	1000	☆

E0.10	Reduction frequency pulse number	0:Invalid; 1~65535	0	☆
E0.11	Reduction frequency	0.00Hz~F0.19(Max frequency)	5.00Hz	☆

5-1-16.E1 Group, Multi-speed, Simple PLC

Code	Parameter name	Setting range	Factory setting	Change
E1.00	0-stage speed setting 0X	-100.0%~100.0%	0.0%	☆
E1.01	1-stage speed setting 1X	-100.0%~100.0%	0.0%	☆
E1.02	2-stage speed setting 2X	-100.0%~100.0%	0.0%	☆
E1.03	3-stage speed setting 3X	-100.0%~100.0%	0.0%	☆
E1.04	4-stage speed setting 4X	-100.0%~100.0%	0.0%	☆
E1.05	5-stage speed setting 5X	-100.0%~100.0%	0.0%	☆
E1.06	6-stage speed setting 6X	-100.0%~100.0%	0.0%	☆
E1.07	7-stage speed setting 7X	-100.0%~100.0%	0.0%	☆
E1.08	8-stage speed setting 8X	-100.0%~100.0%	0.0%	☆
E1.09	9-stage speed setting 9X	-100.0%~100.0%	0.0%	☆
E1.10	10-stage speed setting 10X	-100.0%~100.0%	0.0%	☆
E1.11	11-stage speed setting 11X	-100.0%~100.0%	0.0%	☆
E1.12	12-stage speed setting 12X	-100.0%~100.0%	0.0%	☆
E1.13	13-stage speed setting 13X	-100.0%~100.0%	0.0%	☆
E1.14	14-stage speed setting 14X	-100.0%~100.0%	0.0%	☆
E1.15	15-stage speed setting 15X	-100.0%~100.0%	0.0%	☆
E1.16	Simple PLC running mode	0: Stop after single running 1: Hold final value after single running 2: Circulating	0	☆
E1.17	Simple PLC power-down memory selection	Units digit: Power-down memory selection 0: Power-down without memory 1: Power-down with memory Tens digit: Stop memory selection 0: Stop without memory 1: Stop with memory	11	☆
E1.18	0 stage running time T0	0.0s(h)~6500.0s(h)	0.0s(h)	☆
E1.19	0 stage ac/deceleration time selection	0~3	0	☆
E1.20	1 stage running time T1	0.0s(h)~6500.0s(h)	0.0s(h)	☆
E1.21	1 stage ac/deceleration time selection	0~3	0	☆
E1.22	2 stage running time T2	0.0s(h)~6500.0s(h)	0.0s(h)	☆

E1.23	2 stage ac/deceleration time selection	0~3	0	☆
E1.24	3 stage running time T3	0.0s(h)~6500.0s(h)	0.0s(h)	☆
E1.25	3 stage ac/deceleration time selection	0~3	0	☆
E1.26	4 stage running time T4	0.0s(h)~6500.0s(h)	0.0s(h)	☆
E1.27	4 stage ac/deceleration time selection	0~3	0	☆
E1.28	5 stage running time T5	0.0s(h)~6500.0s(h)	0.0s(h)	☆
E1.29	5 stage ac/deceleration time selection	0~3	0	☆
E1.30	6 stage running time T6	0.0s(h)~6500.0s(h)	0.0s(h)	☆
E1.31	6 stage ac/deceleration time selection	0~3	0	☆
E1.32	7 stage running time T7	0.0s(h)~6500.0s(h)	0.0s(h)	☆
E1.33	7 stage ac/deceleration time selection	0~3	0	☆
E1.34	8 stage running time T8	0.0s(h)~6500.0s(h)	0.0s(h)	☆
E1.35	8 stage ac/deceleration time selection	0~3	0	☆
E1.36	9 stage running time T9	0.0s(h)~6500.0s(h)	0.0s(h)	☆
E1.37	9 stage ac/deceleration time selection	0~3	0	☆
E1.38	10 stage running time T10	0.0s(h)~6500.0s(h)	0.0s(h)	☆
E1.39	10 stage ac/deceleration time selection	0~3	0	☆
E1.40	11 stage running time T11	0.0s(h)~6500.0s(h)	0.0s(h)	☆
E1.41	11 stage ac/deceleration time selection	0~3	0	☆
E1.42	12 stage running time T12	0.0s(h)~6500.0s(h)	0.0s(h)	☆
E1.43	12 stage ac/deceleration time selection	0~3	0	☆
E1.44	13 stage running time T13	0.0s(h)~6500.0s(h)	0.0s(h)	☆
E1.45	13 stage ac/deceleration time selection	0~3	0	☆
E1.46	14 stage running time T14	0.0s(h)~6500.0s(h)	0.0s(h)	☆
E1.47	14 stage ac/deceleration time selection	0~3	0	☆
E1.48	15 stage running time T15	0.0s(h)~6500.0s(h)	0.0s(h)	☆
E1.49	15 stage ac/deceleration time selection	0~3	0	☆
E1.50	Simple PLC run-time unit	0: S (Seconds) 1: H (hours)	0	☆

E1.51	Multi-stage command 0 reference manner	0: Function code E1.00 reference 1: Analog AI1 reference 2: Analog AI2 reference 3: Panel potentiometer setting 4: High-speed pulse setting 5: PID control setting 6: Keyboard set frequency (F0.01) setting, UP/DOWN can be modified 7. Analog AI3 given	0	☆
-------	--	--	---	---

5-1-17.E2 Group - PID function

Code	Parameter name	Setting range	Factory setting	Change
E2.00	PID setting source	0: E2.01 setting 1: Analog AI1 reference 2: Analog AI2 reference 3: Panel potentiometer setting 4: High-speed pulse setting 5: Communications reference 6: Multi-stage command reference	0	☆
E2.01	PID keyboard reference	0.0%~100.0%	50.0%	☆
E2.02	PID feedback source	0: Analog AI1 reference 1: Analog AI2 reference 2: Panel potentiometer setting 3: AI1-AI2 reference 4: High-speed pulse setting 5: Communications reference 6: AI1+AI2 reference 7: MAX(AI1 , AI2) reference 8: MIN (AI1 , AI2) reference 9: Analog AI3 reference	0	☆
E2.03	PID action direction	0: Positive 1: Negative	0	☆
E2.04	PID setting feedback range	0~65535	1000	☆
E2.05	PID inversion cutoff frequency	0.00~F0.19(Maximum frequency)	0.00Hz	☆
E2.06	PID deviation limit	0.0%~100.0%	2.0%	☆
E2.07	PID differential limiting	0.00%~100.00%	0.10%	☆
E2.08	PID reference change time	0.00s~650.00s	0.00s	☆
E2.09	PID feedback filter time	0.00s~60.00s	0.00s	☆
E2.10	PID output filter time	0.00s~60.00s	0.00s	☆
E2.11	PID feedback loss detection value	0.0%: Not judged feedback loss 0.1%~100.0%	0.0%	☆
E2.12	PID feedback loss detection time	0.0s~20.0s	0.0s	☆
E2.13	Proportional gain KP1	0.0~200.0	80.0	☆
E2.14	Integration time Ti1	0.01s~10.00s	0.50s	☆
E2.15	Differential time Td1	0.00s~10.000s	0.000s	☆

E2.16	Proportional gain KP2	0.0~200.0	20.0	☆
E2.17	Integration time Ti2	0.01s~10.00s	2.00s	☆
E2.18	Differential time Td2	0.00~10.000	0.000s	☆
E2.19	PID parameter switching conditions	0: No switching 1: Switching via terminals 2: Automatically switching according to deviation.	0	☆
E2.20	PID parameter switching deviation 1	0.0%~E2.21	20.0%	☆
E2.21	PID parameter switching deviation 2	E2.20~100.0%	80.0%	☆
E2.22	PID integral properties	Units digit: integral separation 0: Invalid; 1: Valid Tens digit: Whether stop integration when output reaches limit 0: Continue; 1: Stop	00	☆
E2.23	PID initial value	0.0%~100.0%	0.0%	☆
E2.24	PID initial value hold time	0.00s~360.00s	0.00s	☆
E2.25	Maximum deviation of twice outputs(Forward)	0.00%~100.00%	1.00%	☆
E2.26	Maximum deviation of twice outputs(Backward)	0.00%~100.00%	1.00%	☆
E2.27	Computing status after PID stop	0: Stop without computing 1: Stop with computing	1	☆
E2.28	reserved			
E2.29	PID automatic decrease frequency selection	0:Invalid; 1:Valid	1	☆
E2.30	PID stop frequency	0.00Hz~maximum frequency (F0.19)	25	☆
E2.31	PID checking time	0s~3600s	10	☆
E2.32	PID checking times	1~500	20	☆

5-1-18.E3 Group – Virtual DI、Virtual DO

Code	Parameter name	Setting range	Factory setting	Change
E3.00	Virtual VDI1 terminal function selection	0~50	0	★
E3.01	Virtual VDI2 terminal function selection	0~50	0	★
E3.02	Virtual VDI3 terminal function selection	0~50	0	★
E3.03	Virtual VDI4 terminal function selection	0~50	0	★
E3.04	Virtual VDI5 terminal function selection	0~50	0	★
E3.05	Virtual VDI terminal status set	Units digit:Virtual VDI1 Tens digit:Virtual VDI2 Hundreds digit:Virtual VDI3 Thousands digit:Virtual VDI4	00000	★

		Tens of thousands:Virtual VDI5		
E3.06	Virtual VDI terminal effective status set mode	Units digit:Virtual VDI1 Tens digit:Virtual VDI2 Hundreds digit:Virtual VDI3 Thousands digit:Virtual VDI4 Tens of thousands:Virtual VDI5	11111	★
E3.07	AI1 terminal as a function selection of DI	0~50	0	★
E3.08	AI2 terminal as a function selection of DI	0~50	0	★
E3.09	Panel potentiometer as a function selection of DI	0~50		
E3.10	AI as DI effective mode selection	Units digit:AI1 0:High level effectively 1:Low level effectively Tens digit:AI2(0~1,same as units digit) Hundreds digit: Panel potentiometer(0~1,same as units digit)	000	★
E3.11	Virtual VDO1 output function selection	0~40	0	☆
E3.12	Virtual VDO2 output function	0~40	0	☆
E3.13	Virtual VDO3 output function	0~40	0	☆
E3.14	Virtual VDO4 output function	0~40	0	☆
E3.15	Virtual VDO5 output function	0~40	0	☆
E3.16	VDO output terminal effective status selection	Units digit:VDO1 0:Positive logic 1:Negative logic Tens digit: VDO2(0~1,same as above) Hundreds digit:VDO3(0~1,same as above) Thousands digit:VDO4(0~1,same as above) Tens of thousands digit:VDO5(0~1,same as above)	00000	☆
E3.17	VDO1 output delay time	0.0s~3600.0s	0.0s	☆
E3.18	VDO2 output delay time	0.0s~3600.0s	0.0s	☆
E3.19	VDO3 output delay time	0.0s~3600.0s	0.0s	☆
E3.20	VDO4 output delay time	0.0s~3600.0s	0.0s	☆
E3.21	VDO5 output delay time	0.0s~3600.0s	0.0s	☆

5-1-19.b0 Group -Motor parameters

Code	Parameter name	Setting range	Factory setting	Change
b0.00	Motor type selection	0: General asynchronous motor	0	★

		1: Asynchronous inverter motor 2: Retain		
b0.01	Rated power	0.1kW~1000.0kW	Depends on models	★
b0.02	Rated voltage	1V~2000V	Depends on models	★
b0.03	Rated current	0.01A~655.35A (Inverter power \leq 55kW) 0.1A~6553.5A (Inverter rate > 55kW)	Depends on models	★
b0.04	Rated frequency	0.01Hz~F0.19 (Maximum frequency)	Depends on models	★
b0.05	Rated speed	1rpm~36000rpm	Depends on models	★
b0.06	Asynchronous motor stator resistance	0.001 Ω ~65.535 Ω (Inverter power \leq 55kW) 0.0001 Ω ~6.5535 Ω (Inverter power > 55kW)	Motor parameters	★
b0.07	Asynchronous motor rotor resistance	0.001 Ω ~65.535 Ω (Inverter power \leq 55kW) 0.0001 Ω ~6.5535 Ω (Inverter power > 55kW)	Motor parameters	★
b0.08	Asynchronous motor leakage inductance	0.01mH~655.35mH (Inverter power \leq 55kW) 0.001mH~65.535mH (Inverter power > 55kW)	Motor parameters	★
b0.09	Asynchronous motor mutUal inductance	0.1mH~6553.5mH (Inverter power \leq 55kW) 0.01mH~655.35mH (Inverter power > 55kW)	Motor parameters	★
b0.10	Asynchronous motor no-load current	0.01A~b0.03 (Inverter power \leq 55kW) 0.1A~b0.03 (Inverter power > 55kW)	Motor parameters	★
b0.27	Motor parameter auto tuning	0: No operation 1: Asynchronous motor parameters still auto tuning 2: Asynchronous motor parameters comprehensive auto tuning 11: Synchronous motor parameters still auto tuning 12: Synchronous motor parameters comprehensive auto tuning	0	★
b0.28	Encoder type	0: ABZ incremental encoder 1: UVW incremental encoder 2: Rotational transformer 3: Sine and cosine encoder 4: Wire-saving UVW encoder	0	★
b0.29	Encoder every turn pulse number	1~65535	2500	★
b0.30	Encoder installation angle	0.00~359.90	0.00	★
b0.31	ABZ incremental encoder AB phase sequence	0: Forward 1: Reverse	0	★
b0.32	UVW encoder offset angle	0.00~359.90	0.0	★
b0.33	UVW encoder UVW phase sequence	0: Forward 1: Reverse	0	★

b0.34	Speed feedback PG disconnection detection time	0.0s: OFF 0.1s~10.0s	0.0s	★
b0.35	Pole-pairs of rotary transformer	1~65535	1	★

5-1-20.y0 Group - Function code management

Code	Parameter name	Setting range	Factory setting	Change
y0.00	Parameter initialization	0: No operation 1: Restore default parameter values, not including motor parameters 2: Clear history 3: Restore default parameter values, including motor parameters 4: Backup current user parameters 501: Restore from backup user parameters 10: Clear keyboard storage area3 11: Upload parameter to keyboard storage area 1 12: Upload parameter to keyboard storage area 2 21: Download the parameters from keyboard storage 1 area to the storage system 3 22: Download the parameters from keyboard storage 2 area to the storage system 3	0	★
y0.01	User password	0~65535	0	☆
y0.02	Function parameter group display selection	Units digit: D group display selection 0: Not displays 1: Displays Tens digit: E group display selection(The same above) Hundreds digit:b group display selection(The same above) Thousands digit:y1 group display selection(The same above) Tens thousands digit:L group display selection(The same above)	11111	★
y0.03	Personality parameter group display selection	Units digit:User's customization parameter display selection 0:Not display 1:Display Tens digit :User's change parameter display selection 0:Not display 1:Display	00	☆
y0.04	Function code modification properties	0: Modifiable 1: Not modifiable	0	☆

5-1-21.y1 Group -Fault query

Code	Parameter name	Setting range	Factory setting	Change
y1.00	Type of the first fault	0: No fault	-	●
y1.01	Type of the second fault	1: Inverter unit protection 2: Acceleration overcurrent	-	●
y1.02	Type of the third(at last)	3: Deceleration overcurrent	-	●

	fault	4: Constant speed overcurrent 5: Acceleration overvoltage 6: Deceleration overvoltage 7: Constant speed overvoltage 8: Control power failure 9: Undervoltage 10: Inverter overload 11: Motor Overload 12: Input phase loss 13: Output phase loss 14: Module overheating 15: External fault 16: Communication abnormal 17: Contactor abnormal 18: Current detection abnormal 19: Motor self-learning abnormal 20: Encoder/PG card abnormal 21: Parameter read and write abnormal 22: Inverter hardware abnormal 23: Motor short to ground 24: Reserved 25: Reserved 26: Running time arrival 27: Custom fault 1 28: Custom fault 2 29: Power-on time arrival 30: Load drop 31: PID feedback loss when running 40: Fast current limiting timeout 41: Switch motor when running 42: Too large speed deviation 43: Motor overspeed 45: Motor over-temperature 51: Initial position error COF: Communication failure		
y1.03	Frequency of the third(at last) fault	-	-	●
y1.04	Current of the third(at last) fault	-	-	●
y1.05	Bus voltage of the third(at last) fault	-	-	●
y1.06	Input terminal status of the third(at last) fault	-	-	●
y1.07	Output terminal status of the third(at last) fault	-	-	●
y1.08	Reserved	-		
y1.09	Power-on time of the third(at last) fault		-	●
y1.10	Running time of the third(at last) fault	-	-	●
y1.11	Reserve	-		

y1.12	Reserve			
y1.13	Frequency of the second fault		-	●
y1.14	Current of the second fault	-	-	●
y1.15	Bus voltage of the second fault	-	-	●
y1.16	Input terminal status of the second fault	-	-	●
y1.17	Output terminal status of the second fault	-	-	●
y1.18	Reserved	-		
y1.19	Power-on time of the second fault		-	●
y1.20	Running time of the second fault	-	-	●
y1.21	Reserve	-		
y1.22	Reserve			
y1.23	Frequency of the first fault		-	●
y1.24	Current of the first fault	-	-	●
y1.25	Bus voltage of the first fault	-	-	●
y1.26	Input terminal status of the first fault	-	-	●
y1.27	Output terminal status of the first fault	-	-	●
y1.28	Reserved	-		
y1.29	Power-on time of the first fault		-	●
y1.30	Running time of the first fault	-	-	●

Chapter 6 Troubleshooting

6-1. Fault alarm and countermeasures

PI500 inverter system operation in the process of failure, the inverter will protect the motor immediately to stop the output, while the inverter fault relay contact action. Inverter panel will display the fault code, the fault code corresponding to the type of fault and common solutions refer to the following table. List for reference only, please do not repair, transformation, if you can not get rid of the trouble, please division or product agents to seek technical support.

No.	Fault ID	Failure type	Possible causes	Solutions
1	Err.01	Inverter unit protection	<ol style="list-style-type: none"> 1.The short circuit of inverter output happens 2.The wiring for the motor and the inverter is too long 3.Module overheating 4.The internal wiring of inverter is loose 5.The main control panel is abnormal 6.The drive panel is abnormal. 7.The inverter module is abnormal 	<ol style="list-style-type: none"> 1.Eliminate peripheral faults 2.Additionally install the reactor or the output filter 3.Check the air duct is blocked or not and the fan is working normally or not, and eliminate problems 4.Correctly plug all cables 5.Seek for technical support
2	Err.02	Acceleration overcurrent	<ol style="list-style-type: none"> 1.The acceleration time is too short 2.Manual torque boost or V/F curve is not suitable 3.The voltage is low 4.The short-circuit or earthing of inverter output happens 5.The control mode is vector and without identification of parameters 6.The motor that is rotating is started unexpectedly. 7.Suddenly increase the load in the process of acceleration. 8.The type selection of inverter is small 	<ol style="list-style-type: none"> 1.Increase acceleration time 2.Adjust manual torque boost or V/F curve 3.Set the voltage to the normal range 4.Eliminate peripheral faults 5.Perform identification for the motor parameters 6.Select Speed Tracking Start or restart after stopping the motor. 7.Cancel the sudden load 8.Choose the inverter with large power level
3	Err.03	Deceleration overcurrent	<ol style="list-style-type: none"> 1.The short-circuit or earthing of inverter output happens 2.The control mode is vector and without identification of parameters 3.The deceleration time is too short 4.The voltage is low 5.Suddenly increase the load in the process of deceleration. 6.Didn't install braking unit and braking resistor 	<ol style="list-style-type: none"> 1.Eliminate peripheral faults 2.Perform identification for the motor parameters 3.Increase the deceleration time 4.Set the voltage to the normal range 5.Cancel the sudden load 6.Install braking unit and brake resistor
4	Err.04	Constant speed overcurrent	<ol style="list-style-type: none"> 1.The short-circuit or earthing of inverter output happens 	<ol style="list-style-type: none"> 1.Eliminate peripheral faults 2.Perform identification for the

No.	Fault ID	Failure type	Possible causes	Solutions
			2.The control mode is vector and without identification of parameters 3.The voltage is low 4. whether suddenly increase the load when running 5.The type selection of inverter is small	motor parameters 3.Set the voltage to the normal range 4.Cancel the sudden load 5.Choose the inverter with large power level
5	Err.05	Acceleration overvoltage	1.Didn't install braking unit and braking resistor 2.The input voltage is high 3.There is external force to drag the motor to run when accelerating. 4.The acceleration time is too short	1.Install braking unit and brake resistor 2.Set the voltage to the normal range 3.Cancel the external force or install braking resistor. 4.Increase acceleration time
6	Err.06	Deceleration overvoltage	1.The input voltage is high 2.There is external force to drag the motor to run when decelerating. 3.The deceleration time is too short 4.Didn't install braking unit and braking resistor	1.Set the voltage to the normal range 2.Cancel the external force or install braking resistor. 3.Increase the deceleration time 4.Install braking unit and brake resistor
7	Err.07	Constant speed overvoltage	1.There is external force to drag the motor to run when running 2.The input voltage is high	1.Cancel the external force or install braking resistor. 2.Set the voltage to the normal range
8	Err.08	Control power failure	1.The range of input voltage is not within the specification; 2, Frequently reported under pressure fault.	Adjust the voltage to the range of the requirements of specification
9	Err.09	Under voltage fault	1.The momentary power cut 2.The inverter's input voltage is not within the specification 3.The bus voltage is not normal 4.The rectifier bridge and buffer resistance are abnormal 5.The drive panel is abnormal. 6.The control panel is abnormal	1.Reset fault 2.Adjust the voltage to the normal range 3.Seek for technical support
10	Err.10	Inverter overload	1.The type selection of inverter is small 2.Whether the load is too large or the motor stall occurs	1.Choose the inverter with large power level 2.Reduce the load and check the motor and its mechanical conditions
11	Err.11	Motor Overload	1.Power grid voltage is too low 2.Whether the setting motor protection parameters (F8.03) is appropriate or not 3.Whether the load is too large or the motor stall occurs	1.Check the power grid voltage 2.Correctly set this parameter. 3.Reduce the load and check the motor and its mechanical conditions

No.	Fault ID	Failure type	Possible causes	Solutions
12	Err.12	Input phase loss	<ol style="list-style-type: none"> 1.The drive panel is abnormal. 2.The lightning protection plate is abnormal 3.The main control panel is abnormal 4.The three-phase input power is not normal 	<ol style="list-style-type: none"> 1.Replace the drive, the power board or contactor 2.Seek for technical support 3.Check and eliminate the existing problems in the peripheral line
13	Err.13	Output phase loss	<ol style="list-style-type: none"> 1.The lead wires from the inverter to the motor is not normal 2.The inverter's three phase output is unbalanced when the motor is running 3.The drive panel is abnormal. 4.The module is abnormal 	<ol style="list-style-type: none"> 1.Eliminate peripheral faults 2.Check the motor's three-phase winding is normal or not and eliminate faults 3.Seek for technical support
14	Err.14	Module overheating	<ol style="list-style-type: none"> 1.The air duct is blocked 2.The fan is damaged 3.The ambient temperature is too high 4.The module thermistor is damaged 5.The inverter module is damaged 	<ol style="list-style-type: none"> 1.Clean up the air duct 2.Replace the fan 3.Decrease the ambient temperature 4.Replace the thermistor 5.Replace the inverter module
15	Err.15	External equipment fault	Input external fault signal through the multi-function terminal DI	Reset run
16	Err.16	Communication fault	<ol style="list-style-type: none"> 1.The communication cable is not normal 2.The settings for communication expansion card F9.07 are incorrect 3.The settings for communication parameters F9 group are incorrect 4.The host computer is not working properly 	<ol style="list-style-type: none"> 1.Check the communication cable 2.Correctly set the communications expansion card type 3.Correctly set the communication parameters 4.Check the wiring of host computer
17	Err.17	Contacting fault	<ol style="list-style-type: none"> 1.Input phase loss 2.The drive plate and the contact are not normal 	<ol style="list-style-type: none"> 1.Check and eliminate the existing problems in the peripheral line 2.Replace the drive, the power board or contactor
18	Err.18	Current detection fault	<ol style="list-style-type: none"> 1.Check Hall device 2.The drive panel is abnormal. 	<ol style="list-style-type: none"> 1.Replace the drive panel 2.Replace hall device
19	Err.19	Motor parameter auto tuning fault	<ol style="list-style-type: none"> 1.The motor parameters was not set according to the nameplate 2.The identification process of parameter is timeout 	<ol style="list-style-type: none"> 1.Correctly set motor parameter according to the nameplate 2.Check the lead wire from the inverter to the motor
20	Err.20	Disk code fault	<ol style="list-style-type: none"> 1.The encoder is damaged 2.PG card is abnormal 3.The encoder model does not match 4.The encoder connection has 	<ol style="list-style-type: none"> 1.Replace the encoder 2.Replace the PG card 3.Correctly set the encoder model according to the Actual conditions

No.	Fault ID	Failure type	Possible causes	Solutions
			error	4.Eliminate the line fault
21	Err.21	EEPROM read and write fault	EEPROM chip is damaged	Replace the main control panel
22	Err.22	Inverter hardware fault	1.overvoltage 2.overcurrent	1.Eliminate overvoltage fault 2.Eliminate overcurrent fault
23	Err.23	Short-circuit to ground fault	Motor short to ground	Replace the cable or motor
26	Err.26	Cumulative running time arrival fault	Cumulative running time arrival fault	Clear history information by using initialization function parameters
27	Err.27	Custom fault 1	Input custom fault 1 signal through the multi-function terminal DI	Reset run
28	Err.28	Custom fault 2	Input custom fault 2 signal through the multi-function terminal DI	Reset run
29	Err.29	Total power-on time arrival fault	Total power-on time reaches the set value	Clear history information by using initialization function parameters
30	Err.30	Load drop fault	The inverter running current is less than F8.31	Confirm whether the load is removed or not or the settings for parameter(F8.31, F8.32) accord with the Actual operating conditions
31	Err.31	PID feedback loss when running fault	PID feedback is less than the set value of E2.11	Check PID feedback signal or set E2.11 to an appropriate value
40	Err.40	Quick current limiting fault	1.Whether the load is too large or the motor stall occurs 2.The type selection of inverter is small	1.Reduce the load and check the motor and its mechanical conditions 2.Choose the inverter with large power level
41	Err.41	Switch motor when running fault	Change current motor through the terminal when the inverter is running	Switch motor after the inverter stops
42	Err.42	Too large speed deviation fault	1.The setting for Too Large Speed Deviation parameters(F8.15, F8.16) is unreasonable. 2.The setting for encoder parameters is incorrect 3.The parameter was not identified	1.Reasonably set the detection parameters 2.Correctly set encoder parameters 3.Perform identification for the motor parameters
43	Err.43	Motor over speed fault	1.The parameter was not identified 2.The setting for encoder parameters is incorrect 3.The setting for motor overspeed detection parameter(F8.13, F8.14) is unreasonable.	1.Perform identification for the motor parameters 2.Correctly set encoder parameters 3.Reasonably set the detection parameters
45	Err.45	Motor	1.The wiring of temperature	1.Detect the wiring of

No.	Fault ID	Failure type	Possible causes	Solutions
		overtemperature fault	sensor is loose 2.The motor temperature is too high	temperature sensor wiring and eliminate fault. 2.Decrease carrier frequency or take other cooling measures to cool motor
51	Err.51	Initial position error	The deviation between the motor parameters and the actual parameters is too large	Reconfirm the correct motor parameters, focus on whether the rated current is set to too small.
-	COF	Communication failure	1.Keyboard interface control board interface; 2.Keyboard or crystal connector; 3.Control board or keyboard hardware damage; 4.Keyboard line is too long, causing the interference.	1.Detection of keyboard interface, control board interface is abnormal. 2.Detect keyboard, crystal joints are abnormal. 3.Replace control board or keyboard. 4. Consult factory, seek help.

6-2.EMC (Electromagnetic Compatibility)

6-2-1.Definition

Electromagnetic compatibility refers to the ability that the electric equipment runs in an electromagnetic interference environment and implements its function stably without interferences on the electromagnetic environment.

6-2-2.EMC standard

In accordance with the requirements of the Chinese national standard GB/T12668.3, the inverter must comply with the requirements of electromagnetic interference and anti-electromagnetic interference.

Our existing products adopt the latest international standards: IEC/EN61800-3: 2004 (Adjustable speed electrical Power drive systems Part 3: EMC requirements and specific test methods), which is equivalent to the Chinese national standards GB/T12668.3. EC/EN61800-3 assesses the inverter in terms of electromagnetic interference and anti-electronic interference. Electromagnetic interference mainly tests the radiation interference, conduction interference and harmonics interference on the inverter (Necessary for civil inverter).

Anti-electromagnetic interference mainly tests the conduction immunity, radiation immunity, surge immunity, EFTB(Electrical Fast Transient Burs) immunity, ESD immunity and power low frequency end immunity (the specific test items includes: 1. Immunity tests of input voltage sag, interrupt and change; 2.Commutation notch immunity; 3. harmonic input immunity ; 4. input frequency change; 5. input voltage unbalance; 6. input voltage fluctuation). The tests shall be conducted strictly in accordance with the above requirements of IEC/EN61800-3, and our products are installed and used according to the guideline of the Section 7.3 and can provide good electromagnetic compatibility in general industry environment.

6-3.EMC directive

6-3-1.Harmonic effect

The higher harmonics of power supply may damage the inverter. Thus, at some places where the quality of power system is relatively poor, it is recommended to install AC input reactor.

6-3-2.Electromagnetic interference and installation precautions

There are two kinds of electromagnetic interference, one is the interference from electromagnetic noise in the surrounding environment to the inverter, and the other is the interference from the inverter to the surrounding equipment.

Installation Precautions:

- 1) The earth wires of the Inverter and other electric products shall be well grounded;
- 2) The power cables of the inverter power input and output and the cable of weak current signal (e.g. control line) shall not be arranged in parallel but in vertical if possible.
- 3) It is recommended that the output power cables of the inverter shall use shield cables or steel pipe shielded cables and that the shielding layer shall be grounded reliably, the lead cables of the equipment suffering interferences shall use twisted-pair shielded control cables, and the shielding layer shall be grounded reliably.
- 4) When the length of motor cable is longer than 50 meters, it needs to install output filter or reactor.

6-3.3. Remedies for the interference from the surrounding electromagnetic equipment to the inverter

Generally the electromagnetic interference on the inverter is generated by plenty of relays, contactors and electromagnetic brakes installed near the inverter. When the inverter has error action due to the interference, the following measures are recommended:

- 1) Install surge suppressor on the devices generating interference;
- 2) Install filter at the input end of the inverter, please refer to Section 6.3.6 for the specific operations.
- 3) The lead cables of the control signal cable of the inverter and the detection line shall use the shielded cable and the shielding layer shall be grounded reliably.

6-3.4. Remedies for the interference from the inverter to the surrounding electromagnetic equipment

These noise interferences are classified into two types: One is the radiation interference of the inverter, and the other is the conduction interference of the inverter. These two types of interference cause that the surrounding electric equipment suffers from the affect of electromagnetic or electrostatic induction. Further, the surrounding equipment produces error action. For different interferences, please refer to the following remedies:

- 1) Generally the meters, receivers and sensors for measuring and testing have more weak signals. If they are placed nearby the inverter or together with the inverter in the same control cabinet, they easily suffer from interference and thus generate error actions. It is recommended to handle with the following methods: Away from the interference source as far as possible; do not arrange the signal cables with the power cables in parallel and never bind them together; both the signal cables and power cables shall use shielded cables and shall be well grounded; install ferrite magnetic ring (with suppressing frequency of 30 to 1,000MHz) at the output side of the inverter and wind it 2 to 3 turns; install EMC output filter in more severe conditions.
- 2) When the interfered equipment and the inverter use the same power supply, it may cause conduction interference. If the above methods cannot remove the interference, it shall install EMC filter between the inverter and the power supply (refer to Section 6.3.6 for the selection operation);
- 3) The surrounding equipment shall be separately grounded, which can avoid the interference caused by the leakage current of the inverter's grounding wire when common grounding mode is adopted.

6-3.5. Remedies for leakage current

There are two forms of leakage current when using the inverter. One is leakage current to the earth, and the other is leakage current between the cables.

- 1) Factors of affecting leakage current to the earth and its solutions:

There are the distributed capacitance between the lead cables and the earth. The larger the distributed capacitance, the larger the leakage current; the distributed capacitance can be reduced by effectively reducing the distance between the inverter and the motor. The higher the carrier frequency, the larger the leakage current. The leakage current can be reduced by reducing the carrier frequency. However, the carrier frequency reduced may result in the increase of motor noise. Please note that additional installation of reactor is also an effective method to solve leakage

current problem. The leakage current may increase with the increase of circuit current. Therefore, when the motor power is higher, the corresponding leakage current will be higher too.

2) Factors of producing leakage current between the cables and its solutions:

There is the distributed capacitance between the output cables of the inverter. If the current passing lines has higher harmonic, it may cause resonance and thus result in leakage current. If the thermal relay is used, it may generate error action. The solution is to reduce the carrier frequency or install output reactor. It is recommended that the thermal relay shall not be installed in the front of the motor when using the inverter, and that electronic over current protection function of the inverter shall be used instead.

6-3-6. Precautions on installing EMC input filter at the input end of power supply

1) Note: when using the inverter, please follow its rated values strictly. Since the filter belongs to Classification I electric appliances, the metal enclosure of the filter and the metal ground of the installing cabinet shall be well earthed in a large area, and have good conduction continuity, otherwise there may be danger of electric shock and the EMC effect may be greatly affected. Through the EMC test, it is found that the filter ground end and the PE end of the inverter must be connected to the same public earth end, otherwise the EMC effect may be greatly affected.

2) The filter shall be installed at a place close to the input end of the power supply as much as possible.

Chapter 7 Dimension

7-1.Dimension

7-1-1.Product outside drawing, installation size

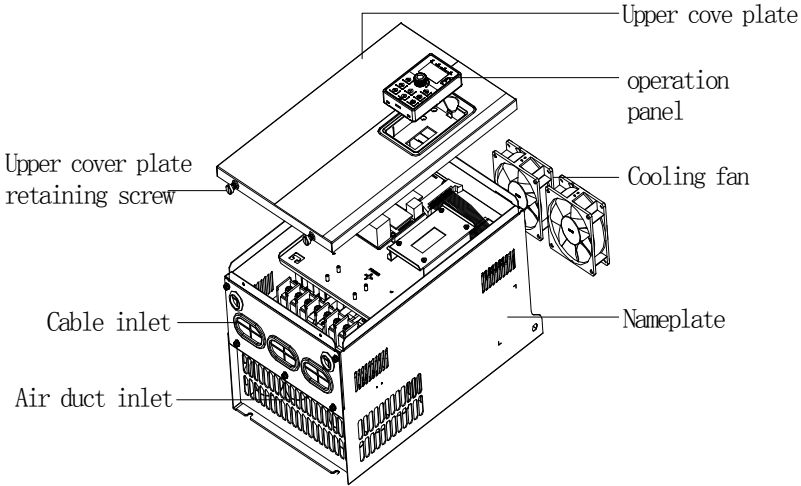
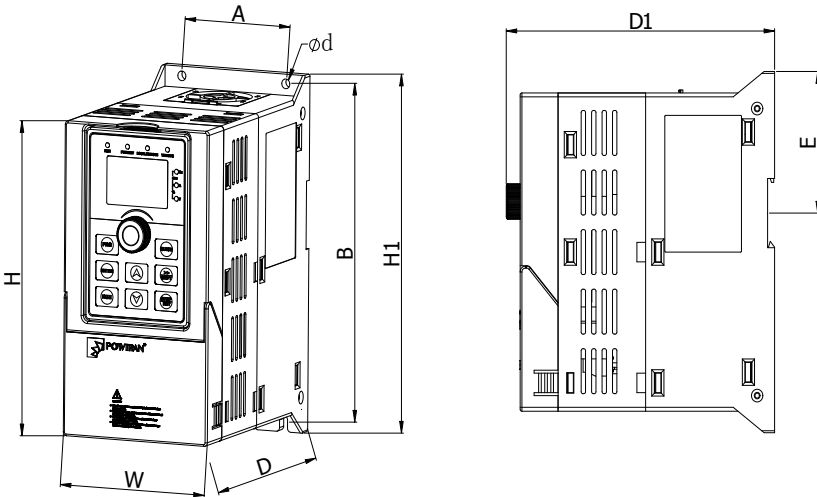

Figure 7-1: 30kW F3 above Product outside drawing, installation dimension

7-1-2.PI500 series



NOTE:0.75~4kW G3 support Rail installation

Figure 7-2: 0.75~4kW G3Dimension

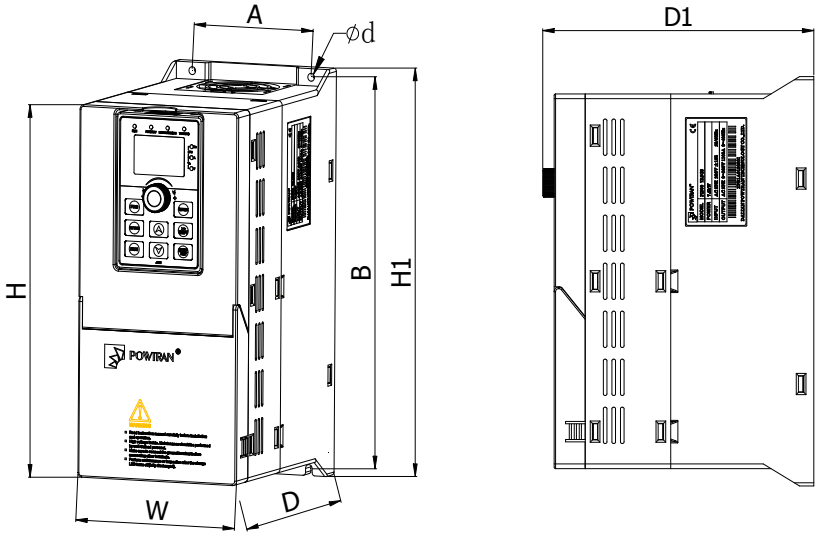

Figure 7-3: 5.5~11kW G3 Dimension

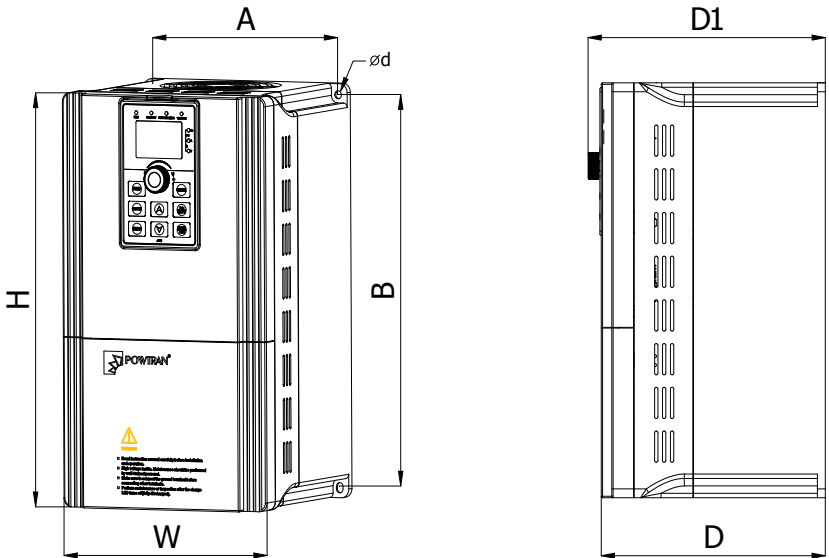

Figure 7-4: 15~22kW G3 Dimension

7-1-2-1. Plastic shell series:

1) Outline dimension drawing and installation dimension of single phase 220 V AC

Model	Output power (kW)	Dimension (mm)					Installation (mm)			Guide rail installation position	Weight (kg)
		H	HI	W	D	DI	A	B	d	E	
PI500 0R4G1	0.4	163	185	90	146	154	65	174	5	72.5	1.6
PI500 0R7G1	0.75										
PI500 1R5G1	1.5	163	185	90	166	174	65	174	5	72.5	1.8
PI500 2R2G1	2.2										
PI500 004G1	4	238	260	120	182	190	90	250	5	/	2.7
PI500 5R5G1	5.5	290	/	170	193	201	155	276	5	/	5.8
PI500 7R5G1	7.5										

2) Outline dimension drawing and installation dimension of three phase 220 V AC

Model	Output power (kW)	Dimension (mm)					Installation (mm)			Guide rail installation position	Weight (kg)
		H	HI	W	D	DI	A	B	d	E	
PI500 0R4G2	0.4	163	185	90	146	154	65	174	5	72.5	1.6
PI500 0R7G2	0.75										
PI500 1R5G2	1.5										
PI500 2R2G2	2.2	163	185	90	166	174	65	174	5	72.5	1.8
PI500 004G2	4	238	260	120	182	190	90	250	5	/	2.7
PI500 5R5G2	5.5										
PI500 7R5G2	7.5	290	/	170	193	201	155	276	5	/	5.8
PI500 011G2	11										

3) Three phase 380V AC outline dimension drawing and installation dimension

Model	Output power (kW)	Dimension (mm)					Installation (mm)			Guide rail installation position	Weight (kg)
		H	HI	W	D	DI	A	B	d	E	
PI500 0R7G3	0.75	163	185	90	146	154	65	174	5	72.5	1.6
PI500 1R5G3	1.5										
PI500 2R2G3	2.2										
PI500 004G3	4	163	185	90	166	174	65	174	5	72.5	1.8
PI500 5R5G3	5.5	238	260	120	182	190	90	250	5	/	2.7
PI500 7R5G3	7.5										
PI500 011F3	11										
PI500 011G3	11										

Model	Output power (kW)	Dimension (mm)					Installation (mm)			Guide rail installation position	Weight (kg)
		H	H1	W	D	D1	A	B	d	E	
PI500 015F3	15	290	/	170	193	201	155	276	5	/	5.8
PI500 015G3/018F3	15/18.5										
PI500 018G3/022F3	18.5/22										
PI500 022G3	22										

4) Three phase 480v AC outline dimension drawing and installation dimension

Model	Output power (kW)	Dimension (mm)					Installation (mm)			Guide rail installation position	Weight (kg)
		H	H1	W	D	D1	A	B	d	E	
PI500 0R7G4	0.75	163	185	90	146	154	65	174	5	72.5	1.6
PI500 1R5G4	1.5										
PI500 2R2G4	2.2										
PI500 004G4	4	163	185	90	166	174	65	174	5	72.5	1.8
PI500 5R5G4	5.5	238	260	120	182	190	90	250	5	/	2.7
PI500 7R5G4	7.5										
PI500 011G4	11										
PI500 011F4	11										
PI500 015F4	15	290	/	170	193	201	155	276	5	/	5.8
PI500 015G4/018F4	15/18.5										
PI500 018G4/022F4	18.5/22										
PI500 022G4	22										

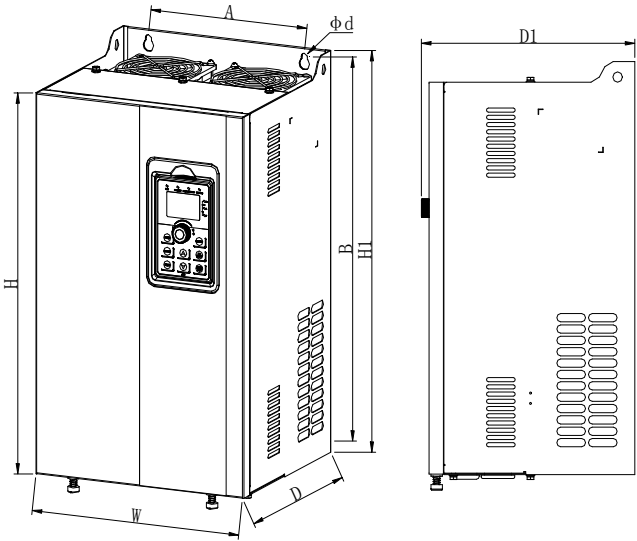

Figure 7-5: 30~220kW G3 Dimension

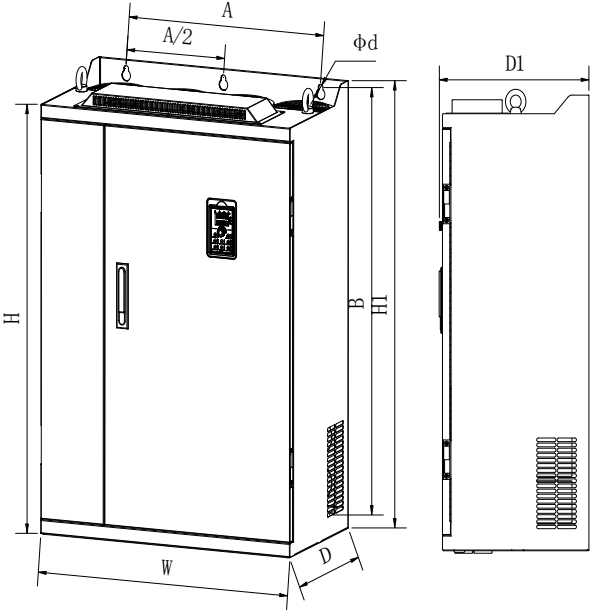

Figure 7-6: 250~400kW G3 Dimension

7-1-2-2. Iron shell wall hanging series:

1). Outline dimension drawing and installation dimension of single phase 220 V AC

Model	Output power (kW)	Dimension (mm)					Installation (mm)			Weight (kg)
		H	HI	W	D	DI	A	B	d	
PI500 011G1	11	330	350	210	190	198	150	335	6	9.5

2). Outline dimension drawing and installation dimension of three phase 220 V AC

Model	Output power (kW)	Dimension (mm)					Installation (mm)			Weight (kg)
		H	HI	W	D	DI	A	B	d	
PI500 015G2	15	380	400	240	215	223	180	385	7	13
PI500 018G2	18.5									
PI500 022G2	22	500	520	300	275	283	220	500	10	42
PI500 030G2	30									
PI500 037G2	37									
PI500 045G2	45	550	575	355	320	328	250	555	10	58
PI500 055G2	55									
PI500 075G2	75	695	720	400	360	368	300	700	10	73
PI500 093G2	93	790	820	480	390	398	370	800	11	108
PI500 110G2	110									
PI500 132G2	132	940	980	705	410	418	550	945	13	190
PI500 160G2	160									

3). Three phase 380V AC outline dimension drawing and installation dimension

Model	Output power (kW)	Dimension (mm)					Installation (mm)			Weight (kg)
		H	HI	W	D	DI	A	B	d	
PI500 030F3	30	330	350	210	190	198	150	335	6	9.5
PI500 030G3	30									
PI500 037F3	37	380	400	240	215	223	180	385	7	13
PI500 037G3/045F3	37/45									
PI500 045G3	45	500	520	300	275	283	220	500	10	42
PI500 055F3	55									
PI500 055G3	55									
PI500 075F3	75	550	575	355	320	328	250	555	10	58
PI500 075G3	75									
PI500 093F3	93	695	720	400	360	368	300	700	10	73
PI500 093G3/110F3	93/110									
PI500 110G3/132F3	110/132									
PI500 132G3	132	940	980	705	410	418	550	945	13	190
PI500 160F3	160									

Model	Output power (kW)	Dimension (mm)					Installation (mm)			Weight (kg)
		H	HI	W	D	DI	A	B	d	
PI500 160G3/187F3	160/187	790	820	480	390	398	370	800	11	108
PI500 187G3/200F3	187/200									
PI500 200G3/220F3	200/220									
PI500 220G3	220	940	980	560	410	418	415	945	13	153
PI500 250F3	250									
PI500 250G3/280F3	250/280									
PI500 280G3	280	940	980	705	410	418	550	945	13	190
PI500 315F3	315									
PI500 315G3/355F3	315/355									
PI500 355G3/400F3	355/400	940	980	705	410	418	550	945	13	190
PI500 400G3	400									

4). Three phase 480V AC outline dimension drawing and installation dimension

Model	Output power (kW)	Dimension (mm)					Installation (mm)			Weight (kg)
		H	HI	W	D	DI	A	B	d	
PI500 030F4	30	330	350	210	190	198	150	335	6	9.5
PI500 030G4	30									
PI500 037F4	37	380	400	240	215	223	180	385	7	13
PI500 037G4/045F4	37/45									
PI500 045G4	45	380	400	280	215	223	180	385	7	14
PI500 055F4	55									
PI500 055G4	55	500	520	300	275	283	220	500	10	42
PI500 075F4	75									
PI500 075G4	75									
PI500 093F4	93	550	575	355	320	328	250	555	10	58
PI500 093G4/110F4	93/110									
PI500 110G4/132F4	110/132									
PI500 132G4	132	695	720	400	360	368	300	700	10	73
PI500 160F4	160									
PI500 160G4/187F4	160/187	790	820	480	390	398	370	800	11	108
PI500 187G4/200F4	187/200									
PI500 200G4/220F4	200/220									
PI500 220G4	220	940	980	560	410	418	415	945	13	153
PI500 250F4	250									
PI500 250G4/280F4	250/280									

Model	Output power (kW)	Dimension (mm)					Installation (mm)			Weight (kg)
		H	HI	W	D	DI	A	B	d	
PI500 280G4	280	940	980	705	410	418	550	945	13	190
PI500 315F4	315									
PI500 315G4/355F4	315/355									
PI500 355G4/400F4	355/400									
PI500 400G4	400									

5). Outline dimension drawing and installation dimension of three phase 690V AC

Model	Output power (kW)	Dimension (mm)					Installation (mm)			Weight (kg)
		H	HI	W	D	DI	A	B	d	
PI500 011G6/015F6	11/15	380	400	240	215	223	180	385	7	13
PI500 015G6/018F6	15/18.5									
PI500 018G6/022F6	18.5/22									
PI500 022G6/030F6	22/30									
PI500 030G6/037F6	30/37									
PI500 037G6/045F6	37/45	500	520	300	275	283	220	500	10	42
PI500 045G6/055F6	45/55									
PI500 055G6/075F6	55/75									
PI500 075G6/093F6	75/93									
PI500 093G6	93									
PI500 110F6	110	550	575	355	320	328	250	555	10	58
PI500 110G6/132F6	110/132									
PI500 132G6/160F6	132/160									
PI500 160G6/187F6	160/187									
PI500 187G6/200F6	187/200	790	820	480	390	398	370	800	11	108
PI500 200G6/220F6	200/220	940	980	560	410	418	415	945	13	153
PI500 220G6/250F6	220/250									
PI500 250G6/280F6	250/280	940	980	705	410	418	550	945	13	190
PI500 280G6/315F6	280/315									
PI500 315G6/355F6	315/355									
PI500 355G6/400F6	355/400									
PI500 400G6/450F6	400/450									

7-1-3.Specification and type of special customized product

1).Outline dimension drawing and installation dimension of three phase 380V AC

Model	Output power (kW)	Dimension (mm)					Installation (mm)			Weight (kg)
		H	H1	W	D	D1	A	B	d	
PI500 030G3B	30	380	400	280	215	223	180	385	7	14
PI500 037G3B	37									
PI500 045G3B	45									
PI500 055F3B	55									
PI500 055F3N	55									
PI500 055G3B	55	500	520	340	275	283	220	500	10	47
PI500 075G3B	75									

2).Outline dimension drawing and installation dimension of three phase 480V AC

Model	Output power (kW)	Dimension (mm)					Installation (mm)			Weight (kg)
		H	H1	W	D	D1	A	B	d	
PI500 030G4B	30	380	400	280	215	223	180	385	7	14
PI500 037G4B	37									
PI500 045G4B	45									
PI500 055F4B	55									
PI500 055F4N	55									
PI500 055G4B	55	500	520	340	275	283	220	500	10	47
PI500 075G4B	75									

7-1-4.PI500 series (With DC reactor base)

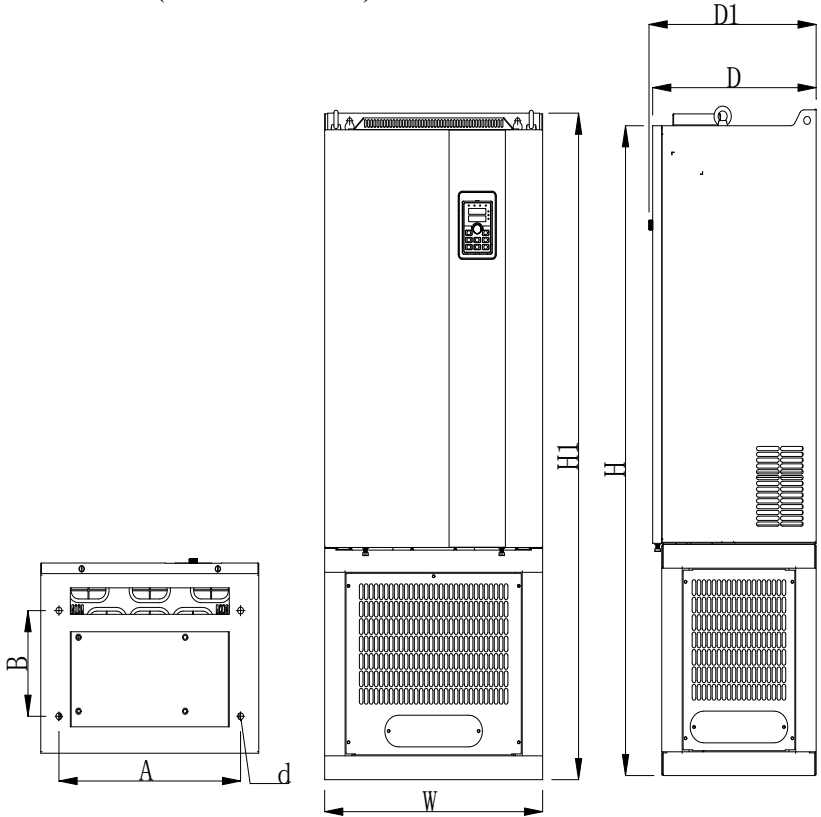

Figure 7-7: 132~220kW G3 (With DC reactor and base)Dimension

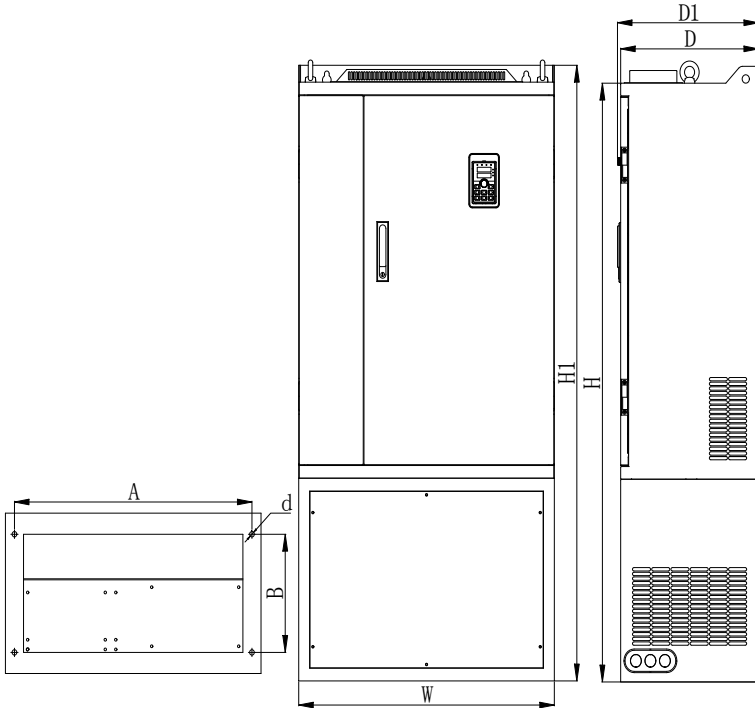

Figure 7-8: 250~400kW G3 (With DC reactor and base)Dimension

7-1-4-1、Iron shell floor mounted series

Outline dimension drawing and installation dimension of three phase 380V AC & three phase 480V AC

Model	Output power (kW)	Dimension (mm)					Installation (mm)			Weight (kg)
		H	H1	W	D	D1	A	B	d	
PI500 132G3R/160F3R	132/160	995	1020	400	360	368	350	270	13*18	115
PI500 132G4R/160F4R										
PI500 160G3R/187F3R	160/187	1230	1260	480	390	398	400	200	13	153
PI500 187G3R/200F3R	187/200									
PI500 200G3R/220F3R	200/220									
PI500 220G3R	220									
PI500 160G4R/187F4R	160/187									
PI500 187G4R/200F4R	187/200									
PI500 200G4R/220F4R	200/220									

PI500 220G4R	220	1419	1460	560	410	418	500	310	13	205
PI500 250F3R	250									
PI500 250G3R/280F3R	250/280									
PI500 280G3R	280									
PI500 250F4R	250									
PI500 250G4R/280F4R	250/280									
PI500 280G4R	280									
PI500 315F3R	315	1419	1460	705	410	418	645	310	13	249.4
PI500 315G3R/355F3R	315/355									
PI500 355G3R/400F3R	355/400									
PI500 400G3R	400									
PI500 315F4R	315									
PI500 315G4R/355F4R	315/355									
PI500 355G4R/400F4R	355/400									
PI500 400G4R	400									

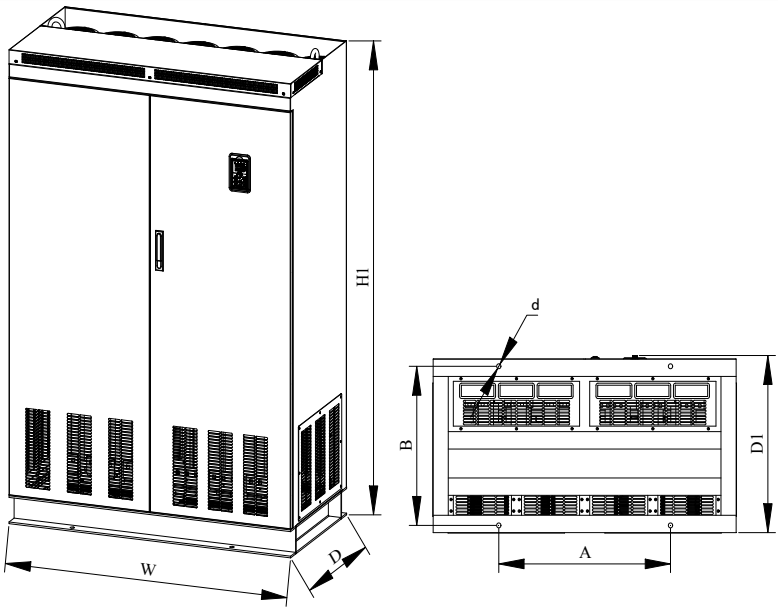

Figure 7-9: 450~630kW G3(DC reactor)Dimension

Iron shell landing installation series

Model	Output power (kW)	Dimension (mm)				Installation(mm)			Weight (kg)
		H	W	D	DI	A	B	d	
PI500 450F3R	450	/	1200	600	612	680	550	17	/
PI500 450G3R/500F3R	450/500								
PI500 500G3R/560F3R	500/560								
PI500 560G3R/630F3R	560/630								
PI500 630G3R/710F3R	630/700								

Note: With the letter "R" means with a DC reactor; product installation rings screw height dimensions: H1 + 15mm.

7-1-5.Keypad dimension drawing

PI500 keyboard size:

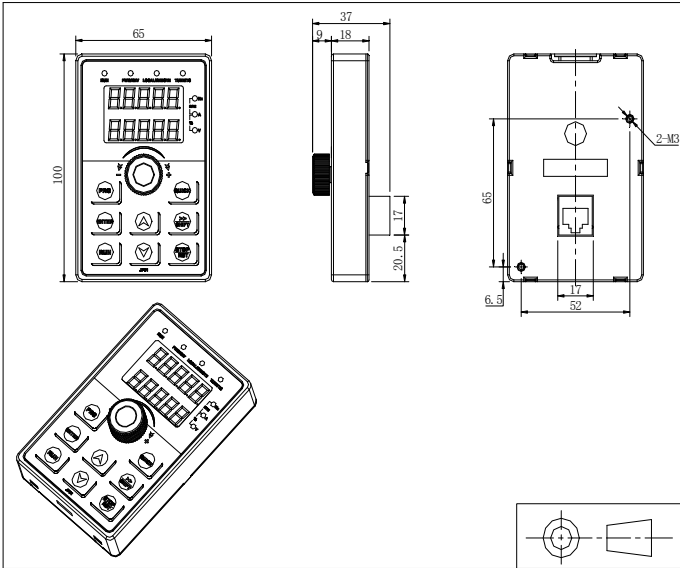

Figure 7-10: PI500 keyboard size (Size: Mm)

PI500 keyboard size chart:

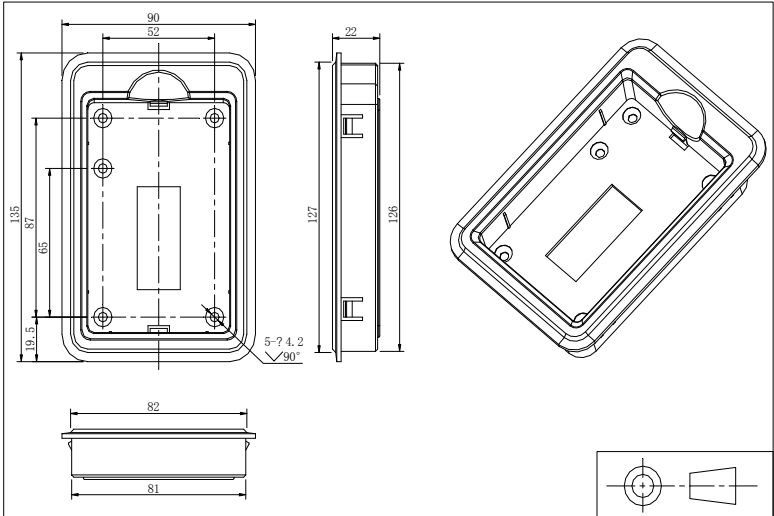

Figure 7-11: Keyboard size chart (Size: Mm)

PI500 keyboard installation opening size:

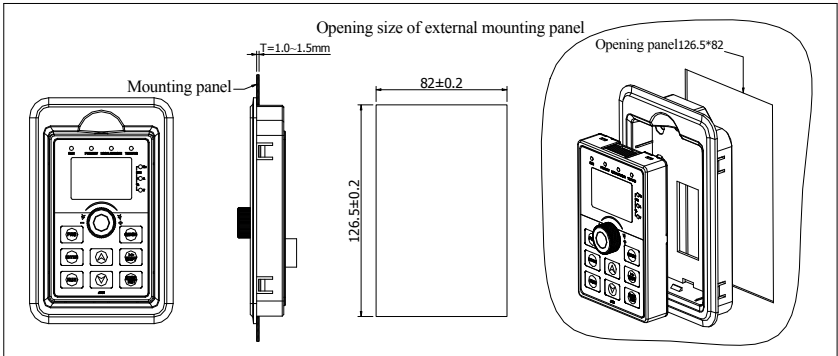

Figure 7-12: Keyboard installation opening size chart (Size: Mm)

Notes:

1. The keyboard compartment is installed on the panel of the inverter with square hole required.
2. The overall dimension of LED keyboard is fully compatible with that of LCD keyboard.

Chapter 8 Maintenance and repair

8-1. Inspection and maintenance

During normal use of the inverter, in addition to routine inspections, the regular inspections are required (e.g. the overhaul or the specified interval, and the interval shall not exceed 6 months), please refer to the following table to implement the preventive measures.

Check Date		Check Points	Check Items	Check to be done	Method	Criterion
Routine	Regular					
√		Display	LED display	Whether display is abnormal or not	Visually check	As per use status
√	√	Cooling system	Fan	Whether abnormal noise or vibration exists or not	Visually and audibly check	No abnormal
√		Body	Surrounding conditions	Temperature, humidity, dust, harmful gas.	Visually check with smelling and feeling	As per Section 2-1
√		Input/output terminals	Voltage	Whether input/output voltage is abnormal or not	Test R, S, T and U, V, W terminals	As per standard specifications
	√	Main circuit	Overall	Whether these phenomenon of loose fastenings, overheat, discharging, much dust, or blocked air duct exist or not	Visually check, tighten and clean	No abnormal
			Electrolytic capacitance	Whether appearance is abnormal or not	Visually check	No abnormal
			Wires and conducting bar	Whether they are loose or not	Visually check	No abnormal
			Terminals	If screws or bolts are loose or not	Tighten	No abnormal

"√" means routine or regular check to be needed

Do not disassemble or shake the device gratuitously during check, and never unplug the connectors, otherwise the system will not run or will enter into fault state and lead to component failure or even damage to the main switching device such as IGBT module.

The different instruments may come to different measurement results when measuring. It is recommended that the pointer voltmeter shall be used for measuring input voltage, the rectifier voltmeter for output voltage, the clamp-on ammeter for input current and output current, and the electric wattmeter for power.

8-2. Parts for regular replacement

To ensure the reliable operation of inverter, in addition to regular care and maintenance, some internal mechanical wear parts (including cooling fan, filtering capacitor of main circuit for energy storage and exchange, and printed circuit board) shall be regularly replaced. Use and replacement for such parts shall follow the provisions of below table, also depend on the specific application environment, load and current status of inverter.

Name of Parts	Standard life time
Cooling fan	1 to 3 years
Filter capacitor	4 to 5 years
Printed circuit board(PCB)	5 to 8 years

8-3.Storage

The following actions must be taken if the inverter is not put into use immediately(temporary or long-term storage) after purchasing:

※It should be store at a well-ventilated site without damp, dust or metal dust, and the ambient temperature complies with the range stipulated by standard specification

※Voltage withstand test can not be arbitrarily implemented, it will reduce the life of inverter. Insulation test can be made with the 500-volt megger before using, the insulation resistance shall not be less than 4MΩ.

8-4.Capacitor

8-4-1.Capacitor rebuilt

If the frequency inverter hasn't been used for a long time, before using it please rebuilt the DC bus capacitor according the instruction. The storage time is counted from delivery.

Time	Operation instruction
Less than 1 year	No need to recharge
Between 1~2 years	Before the first time to use, the frequency inverter must be recharged for one hour
Between 2~3years	Use adjustable power to charge the frequency inverter: --25% rated power 30 minutes, -- 50% rated power 30minutes, -- 75% rated power 30minutes, --Last 100% rated power 30minutes,
More than 3 years	Use adjustable power to charge the frequency inverter: --25% rated power 2hours, --50% rated power 2 hours, -- 75% rated power 2hours, -- Last 100% rated power 2hours.

Instruction of using adjustable power to charge the frequency inverter:

The adjustable power is decided by the frequency inverter input power, for the single phase/3 phase 220v frequency inverter, we use 220v AC/2A Regulator. Both single phase and three phase frequency inverter can be charged by single phase Power Surge(L+ connect R,N connects T) Because it is the same rectifier,so all the DC bus capacitor will be charged at the same time.

You should make sure the voltage(380v) of high voltage frequency inverter, because when the capacitor being charged it almost doesn't need any current, so small capacitor is enough(2A)

The instruction of using resistor(incandescent lights) to charge frequency inverters:

When charge the DC bus capacitor of drive system by connecting power directly, then the time should not be less than 60 minutes. The operation should be carried on under the condition of normal temperature and without load, and moreover ,should be added resistor in the power supply cycle.

380V drive system: use 1K/100W resistor. When the power is less than 380v, 100w incandescent lights is also suitable. When using incandescent lights, the lights will extinct or become very weak.

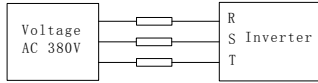

Figure 8-1:380V Drive equipment charging circuit example

8-5.Measuring and readings

※If a general instrument is used to measure current, imbalance will exist for the current at the input terminal. generally, the deviation is not more than 10%, that is normal. If the deviation exceeds 30%, please inform the original manufacturer to replace rectifier bridge, or check if the deviation of three-phase input voltage is above 5V or not.

※If a general multi-meter is used to measure three-phase output voltage, the reading is not accurate due to the interference of carrier frequency and it is only for reference.

Chapter 9 Options

1. Power cables

The dimension of input power cable and motor cable should meet the local provision: Input power cable and motor cable should bear the related load current.

The maximum rated temperature margin conditions of the motor cable should not be sustained below 70 degrees.

Conductivity of the PE conductor and phase conductor capacity are the same (Same cross-sectional area),

About EMC requirements, see "EMC Guidance Content"

To meet the CE EMC requirements, a symmetrical shielded motor cable must be used (See figure below). For input cables can use four-core cable, but still recommended to use shielded symmetrical cable. Compared to a four-core cable, shielded symmetrical cables can not only reduce the loss and cost of the current flowing through the motor cable, but also can reduce the electromagnetic radiation.

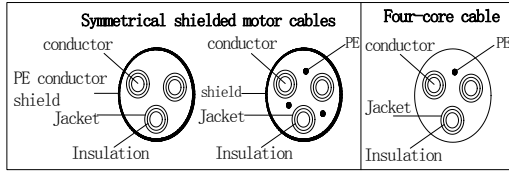

Note: If conductivity of the cable shield can not meet the requirements, you must use a separate PE conductor.

To play a protective role of conductor, when the shield wire and phase conductors using the same material, the cross-sectional area of the shield wire and phase conductors cross-sectional area must be the same, aims to reduce grounding resistance, impedance continuity better.

To effectively suppress RFI transmission and conduction, the shield conductivity must be at least 1/10 of the phase conductor conductivity. For copper or aluminum shield, this requirement is very easy to meet. Minimum requirements for the drive motor cable as shown below. Cable comprising a layer of copper spiral. Shield tight as possible, that the more tightly the more we can effectively suppress radiated electromagnetic interference.

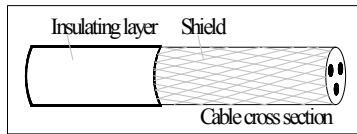

2. Control Cable

All analog control cables and cables for the frequency input must be shielded. Analog signal cable double-shielded twisted pair cable as shown in Figure 1. Each signal uses one pair individually shielded twisted pair cable pair. Do not use the different analog signal with a ground wire.

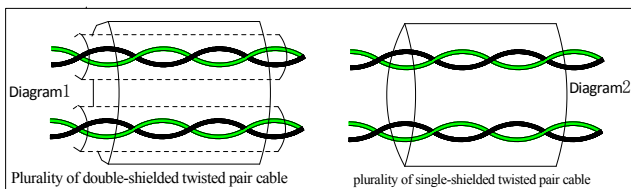

For low-voltage digital signals, double-shielded cable is the best choice, but can also be a single-shielded or unshielded twisted pair, as shown in Figure 2, however, the frequency of the signal, it can only use a shielded cable.

Relay cable need to use cables with metal braid shield.

Need to use a network cable to connect the keyboard, for electromagnetic environment is more complex place, it is recommended to use shielded cable.

Note: Analog and digital signals using different cables routed separately.

3..Interference Counte

Connect noise filter on the output side of inverter can reduce inductive interference and radio interference .

→Inductive interference :The electromagnetic induction makes the signal line noise when upland signal ,and then cause the control equipment malfunction.

→ Wireless interference :The high-frequency electromagnet wave emitted by the inverter and cables will interfere with the nearby wireless device and make it noise when receiving signal.

→ Installation of noise filter as below :

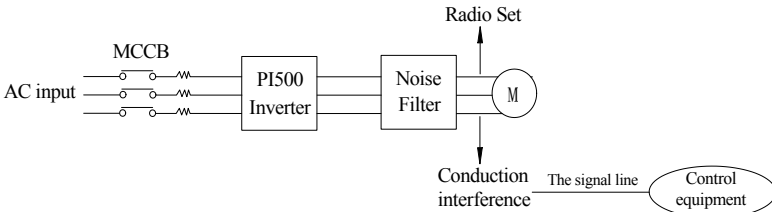

(1)Inductive interference countermeasure : in addition to the installation of noise filter , it can also import the output cables to grounded metal tube. The distance between the output cable and signal line is greater than 30cm , the influence of inductive interference is also significantly reduced . As shown below :

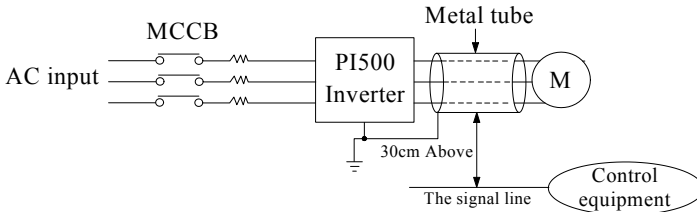

(2)Radio frequency (RF) interference countermeasure : The input cables, output cables and inverter itself can produce interference , to install noise filter on both sides of input and output and shield the inverter with metal box can reduce the radio frequency interference . As shown below :

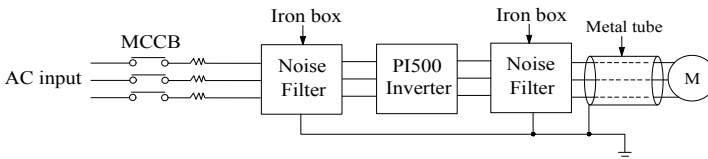

Chapter 10 Warranty

The product quality shall comply with the following provisions (overseas market):

1. Warranty terms

- 1-1. The product from the ex-factory date, the warranty period of 18 months(except non-standard products), It is based on factory records.
- 1-2. The product from the ex-factory date. if the product appear quality problem within the normal operating range. we provide free warranty under 18 months.
- 1-3. The product from the ex-factory date, enjoy lifelong compensable service.
If there is a contract, we will according to the priority principle of the contract.

2. Exceptions clause

If belongs to the quality problems caused by following reasons products, we provide compensable service even though under the warranty. we will charge a maintenance fee.

- 2-1. The user is not in accordance with the "products manual" is used method of operation caused the failure.
- 2-2. Users without permission to alteration or repair caused by product failure.
- 2-3. Users beyond the standard specifications require the use of the inverter caused by product failure.
- 2-4. Users to buy and then fell loss or damage caused by improper handling.
- 2-5. Because the user use adverse environment (Such as: Humid environment, Acid and alkaline corrosion gas and so on) lead to product failure.
- 2-6. Due to the fault cause of earthquake, fire, lightning, wind or water disaster, abnormal voltage irresistible natural disasters.
- 2-7. Damaged during shipping ,but users are not rejected goods.

3. The following conditions, manufacturers have the right not to be warranty.

- 3-1. No product nameplate or product nameplate blurred beyond recognition.
- 3-2. Not according to the purchase contract agreement to pay the money.
- 3-3. For installation, wiring, operation, maintenance and other users can not describe the objective reality to the company's technical service center.

4. About the repair fee, according to our company latest price list as a standard.

5. When the products is broken, please complete the form and warranty card, shipping with the failure machine to our company.

6. Dalian Powtran Technology Co.,Ltd reserve the right to explain the terms of the event.

Appendix I RS485 Communication protocol

I-1 Communication protocol

I-1-1 Communication content

This serial communication protocol defines the transmission information and use format in the series communication Including: Master polling(or broadcast) format; master encoding method, and contents including: function code of action, transferring data and error checking. The response of slave also adopts the same structure, and contents including: Action confirmation, returning the data and error checking etc. If slave takes place the error while it is receiving information or cannot finish the action demanded by master, it will send one fault signal to master as a response.

Application Method

The inverter will be connected into a “Single-master Multi-slave” PC/PLC control network with RS485 bus.

Bus structure

(1)Transmission mode

Asynchronous series and half-duplex transmission mode. For master and slave, only one of them can send the data and the other only receives the data at the same time. In the series asynchronous communication, the data is sent out frame by frame in the form of message

(2)Topological structure

Single-master and multi-slave system. The setting range of slave address is 0 to 247, and 0 refers to broadcast communication address. The address of slave for network must be exclusive.

Figure I-3 is the single inverter and PC set up MODBUS field wiring diagram. Because computers are generally not with RS485 interface, the computer must be built-in RS232 interface or USB interface through the converter to convert to RS485. Connect the T + of converter with 485 + terminal of the inverter, Connect the T- of converter with 485- terminal of inverter. We recommended to use a shielded twisted pair. When adopting the RS232-485 converter,RS232 interface connected with RS232-RS485 RS232 interface, the cable should be as short as possible,15meters at the longest, we recommend to plug the RS232-RS485 with computer in pair directly. Similarly, when using the USB-RS485 converter, cable should be as short as possible.

When the line is connected, connect the right port of the host computer on the computer to (RS232-RS485 converter port, such as COM1), and set the basic parameters and the baud rate and data bit parity and so on consistent with the inverter.

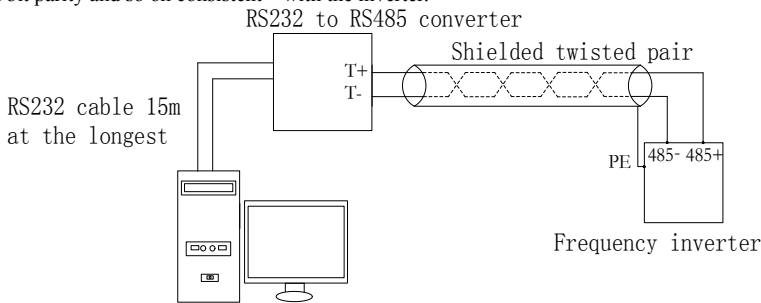

Figure I-3

Multiple Applications

In reality, multi-machine applications, there are two connections

The first inverter and the last inverter short the terminal resistor on the control board to be active. As shown in Figure I-4

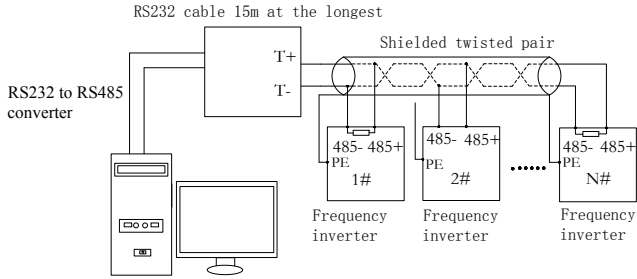

Figure I-4

The two longest distance inverter from the device shall short the terminal resistor on the control board to be active. As shown in Figure I-5:

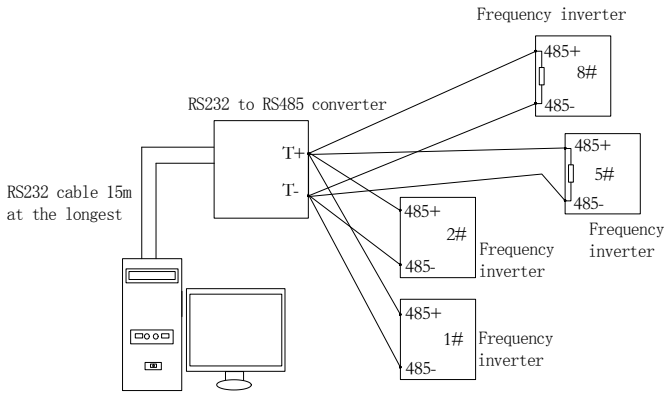

Figure I-5

Multi-machine connection should try to use a shielded cable. The basic parameters such as baud rate and data bit of all of the devices on RS485 line must be the same, address must be different.

NOTE: The terminal resistor of 485 decides valid or invalid through the control board (No. 485) jumper

I-1-2 Protocol description

PI500 series inverter communication protocol is a asynchronous serial master-slave communication protocol, in the network, only one equipment(Master) can build a protocol (known as "Inquiry/Command"). Other equipment(Slave) only can response the "Inquiry/Command"of master by providing data or perform the corresponding action according to the "Inquiry/Command"of master. Here, the master refers to a Personnel Computer(PC), an industrial control device or a programmable logic controller (PLC), etc. and the slave refers to PI500 inverter. Master can communicate with individUal slave, also send broadcasting information to all the lower slaves. For the single "Inquiry/Command"of master, slave will return a signal(that is a response) to master; for the broadcasting information sent by master, slave does not need to feedback a response to master.

Communication data structure PI500 series inverter's Modbus protocol communication data format is as follows: in RTU mode, messages are sent at a silent interval of at least 3.5 characters. There are diverse character intervals under network baud rate,

which is easiest implemented. The first field transmitted is the device address.

The allowable characters for transmitting are hexadecimal 0 ... 9, A ... F. The networked devices continuously monitor network bus, including during the silent intervals. When the first

field (the address field) is received, each device decodes it to find out if it is sent to their own. Following the last transmitted character, a silent interval of at least 3.5 characters marks the end of the message. A new message can begin after this silent interval.

The entire message frame must be transmitted as a continuous stream. If a silent interval of more than 1.5 characters occurs before completion of the frame, the receiving device will flushes the incomplete message and assumes that the next byte will be the address field of a new message. Similarly, if a new message begins earlier than the interval of 3.5 characters following a previous message, the receiving device will consider it as a continuation of the previous message. This will result in an error, because the value in the final CRC field is not right.

RTUframe format :

Frame header START	Time interval of 3.5characters
Slave address ADR	Communication address: 1 to 247
Command code CMD	03: Read slave parameters;06: write slave parameters
Data content DATA(N-1)	Data content: Address of function code parameter, numbers of function code parameter, value of function code parameter, etc.
Data content DATA(N-2)	
.....	
Data content DATA0	
CRC CHK high-order	Detection Value: CRC value.
CRC CHK low-order	
END	Time interval of 3.5characters

CMD (Command) and DATA (data word description)

Command code: 03H, reads N words (Max.12 words), for example: for the inverter with slave address 01, its start address F0.02 continuously reads two values.

Master command information

ADR	01H
CMD	03H
Start address high-order	F0H
Start address low-order	02H
Number of registers high-order	00H
Number of registers low-order	02H
CRC CHK low-order	CRC CHK values are to be calculated
CRC CHK high-order	

Slave responding information

When F9.05 is set to 0:

ADR	01H
CMD	03H
Byte number high-order	00H
Byte number low-order	04H
Data F002H high-order	00H
Data F002H low-order	01H
Data F003H high-order	00H
Data F003H low-order	01H
CRC CHK low-order	CRC CHK values are to be calculated
CRC CHK high-order	

When F9.05is set to 1:

ADR	01H
CMD	03H
Byte number	04H
Data F002H high-order	00H
Data F002H low-order	01H
Data F003H high-order	00H
Data F003H low-order	01H
CRC CHK low-order	CRC CHK values are to be calculated

CRC CHK high-order	
--------------------	--

Command Code: 06H, write a word. For example: Write 5000(1388H) into the address F013H of the inverter with slave address 02H.

Master command information

ADR	02H
CMD	06H
Data address high-order	F0H
Data address low-order	13H
Data content high-order	13H
Data content low-order	88H
CRC CHK low-order	CRC CHK values are to be calculated
CRC CHK high-order	

Slave responding information

ADR	02H
CMD	06H
Data address high-order	F0H
Data address low-order	13H
Data content high-order	13H
Data content low-order	88H
CRC CHK low-order	CRC CHK values are to be calculated
CRC CHK high-order	

I-2 Check mode:

Check mode - CRC mode: CRC (Cyclical Redundancy Check) adopts RTU frame format, the message includes an error-checking field that is based on CRC method. The CRC field checks the whole content of message. The CRC field has two bytes containing a 16-bit binary value. The CRC value calculated by the transmitting device will be added into to the message. The receiving device recalculates the value of the received CRC, and compares the calculated value to the Actual value of the received CRC field, if the two values are not equal, then there is an error in the transmission.

The CRC firstly stores 0xFFFF and then calls for a process to deal with the successive eight-bit bytes in message and the value of the current register. Only the 8-bit data in each character is valid to the CRC, the start bit and stop bit, and parity bit are invalid.

During generation of the CRC, each eight-bit character is exclusive OR(XOR) with the register contents separately, the result moves to the direction of least significant bit(LSB), and the most significant bit(MSB) is filled with 0. LSB will be picked up for detection, if LSB is 1, the register will be XOR with the preset value separately, if LSB is 0, then no XOR takes place. The whole process is repeated eight times. After the last bit (eighth) is completed, the next eight-bit byte will be XOR with the register's current value separately again. The final value of the register is the CRC value that all the bytes of the message have been applied.

When the CRC is appended to the message, the low byte is appended firstly, followed by the high byte. CRC simple functions is as follows:

```
unsigned int crc_chk_value(unsigned char *data_value, unsigned char length)
{
    unsigned int crc_value=0xFFFF;

    int i;
    while(length--)
    {
        crc_value^=*data_value++;
        for(i=0;i<8;i++)
        {
```

```

        if(Crc_value&0x0001)
        {
            crc_value=(C rc_value>>1)^0xa001;
        }
        else
        {
            crc_value=crc_value>>1;
        }
    }
}
return(Crc_value);
}

```

I-3 Definition of communication parameter address

The section is about communication contents, it's used to control the operation, status and related parameter settings of the inverter. Read and write function-code parameters (Some functional code is not changed, only for the manufacturer use or monitoring): The rules of labeling function code parameters address:

The group number and label number of function code is used to indicate the parameter address:

High byte: F0 to FB (F group), A0 to AF (E group), B0 to BF (b group), C0 to C7 (y group), 70 to 7F (d group) low byte: 00 to FF, this should be written EEPROM.

For example: Address F3.12 indicates F30C; Note: L0 group parameters: Neither read nor change; d group parameters: Only read, not change.

Parameter	Corresponding register address	Parameter	Corresponding register address
d0.00~d0.41	7000~7029	FA.00~FA.07	FA00~FA07
F0.00~F0.27	F000~F029	Fb.00~Fb.09	Fb00~Fb09
F1.00~F1.46	F100~F12E	FC.00~FC.02	FC00~FC02
F2.00~F2.19	F200~F213	E0.00~E0.11	A000~A00b
F3.00~F3.15	F300~F30F	E1.00~E1.51	A100~A133
F4.00~F4.14	F400~F40E	E2.00~E2.32	A200~A220
F5.00~F5.15	F500~F50F	E3.00~E3.21	A300~A315
F6.00~F6.21	F600~F615	b0.00~b0.35	B000~B023
F7.00~F7.54	F700~F736	y0.00~y0.04	C000~C004
F8.00~F8.35	F800~F823	y1.00~y1.30	C100~C11e
F9.00~F9.07	F900~F907		

Some parameters can not be changed during operation, but some parameters can not be changed regardless of the inverter is in what state. When changing the function code parameters, please pay attention to the scope, units, and relative instructions on the parameter.

Besides, due to EEPROM is frequently stored, it will reduce the life of EEPROM, therefore under the communication mode some function code do not need to be stored and you just change the RAM value.

If F group parameters need to achieve the function, as long as change high order F of the function code address to 0. If E group parameters need to achieve the function, as long as change high order F of the function code address to 4. The corresponding function code addresses are indicated below: High byte: 00 to 0F (F group), 40 to 4F (E group), 50 to 5F (b group), 60 to 67 (Y group) low byte: 00 to FF, this should be written RAM.

For example:

Function code F3.12 can not be stored into EEPROM, address indicates as 030C; function

code E3.05 can not be stored into EEPROM, address indicates as 4305; the address indicates that only writing RAM can be done and reading can not be done, when reading, it is invalid address. For all parameters, you can also use the command code 07H to achieve the function.

Stop/Run parameters section:

Parameter address	Parameter description	Parameter address	Parameter description
1000	Communication set value(-10000 to10000)(Decimal)	1011	PID feedback
1001	Running frequency	1012	PLC step
1002	Bus voltage	1013	High-speed pulse input frequency, unit: 0.01kHz
1003	Output voltage	1014	Feedback speed, unit:0.1Hz
1004	Output current	1015	Remaining run time
1005	Output power	1016	AI1 voltage before correction
1006	Output torque	1017	AI2 voltage before correction
1007	Operating speed	1018	Reserve
1008	DI input flag	1019	Linear speed
1009	DO output flag	101A	Current power-on time
100A	AI1 voltage	101B	Current run time
100B	AI2 voltage	101C	High-speed pulse input frequency, unit: 1Hz
100C	AI3 voltage	101D	Communication set value
100D	Count value input	101E	Actual feedback speed
100E	Length value input	101F	Master frequency display
100F	Load speed	1020	Auxiliary frequency display
1010	PID setting		

Note:

There is two ways to modify the settings frequencies through communication mode:

The first: Set F0.03 (Main frequency source setting) as 0/1 (Keyboard set frequency), and then modify the settings frequency by modifying F0.01 (Keyboard set frequency). Communication mapping address of F0.01 is 0xF001 (Only need to change the RAM communication mapping address to 0x0001).

The second :Set F0.03 (Main frequency source setting) as 9 (Remote communication set), and then modify the settings frequency by modifying (Communication settings) , mailing address of this parameter is 0x1000.The communication set value is the percentage of the relative value, 10000 corresponds to 100.00%, -10000 corresponds to -100.00%. For frequency dimension data, it is the percentage of the maximum frequency (F0.19); for torque dimension data, the percentage is F5.08 (torque upper limit digital setting).

Control command is input to the inverter: (write only)

Command word address	Command function
2000	0001: Forward run
	0002: Reverse run
	0003: Forward Jog
	0004: Reverse Jog
	0005: Free stop
	0006: Deceleration and stop
	0007: Fault reset

Inverter read status: (read-only)

Status word address	Status word function
3000	0001: Forward run
	0002: Reverse run
	0003: Stop

Parameter lock password verification: (If the return code is 8888H, it indicates that password verification is passed)

Password address	Enter password
C000	*****

Digital output terminal control: (write only)

Command address	Command content
2001	BIT0: SPA output control BIT1: RELAY2 output control BIT2 RELAY1 output control BIT3: Manufacturer reserves the undefined BIT4: SPB switching quantity output control

Analog output DA1 control: (write only)

Command address	Command content
2002	0 to 7FFF indicates 0% to 100%

Analog output DA2 control: (write only)

Command address	Command content
2003	0 to 7FFF indicates 0% to 100%

SPB high-speed pulse output control: (write only)

Command address	Command content
2004	0 to 7FFF indicates 0% to 100%

Inverter fault description:

Inverter fault address:	Inverter fault information:
8000	0000: No fault
	0001: Inverter unit protection
	0002: Acceleration overcurrent
	0003: Deceleration overcurrent
	0004: Constant speed overcurrent
	0005: Acceleration overvoltage
	0006: Deceleration overvoltage
	0007: Constant speed overvoltage
	0008: Control power failure
	0009: Undervoltage fault
	000A: Inverter overload
	000B: Motor Overload
	000C: Input phase loss
	000D: Output phase loss
	000E: Module overheating
000F: External fault	
0010: Communication abnormal	
0011: Contactor abnormal	
0012: Current detection fault	
0013: Motor parameter auto tuning fault	
0014: Encoder/PG card abnormal	

	0015: Parameter read and write abnormal 0016: Inverter hardware fault 0017: Motor short to ground fault 0018: Reserved 0019: Reserved 001A: Running time arrival 001B: Custom fault 1 001C: Custom fault 2 001D: Power-on time arrival 001E: Load drop 001F: PID feedback loss when running 0028: Fast current limiting timeout 0029: Switch motor when running fault 002A: Too large speed deviation 002B: Motor overspeed 002D: Motor overtemperature 005A: Encoder lines setting error 005B: Missed encoder 005C: Initial position error 005E: Speed feedback error
--	---

Data on communication failure information description (Fault code):

Communication fault address	Fault function description
8001	0000: No fault 0001: Password error 0002: Command code error 0003: CRC check error 0004: Invalid address 0005: Invalid parameters 0006: Invalid parameter changes 0007: System locked 0008: EEPROM in operation

F9Group - Communication parameter description

	Baud rate	Default	6005
F9.00	Setting range	Units digit: MODUBUS baud rate 0: 300BPS 1: 600BPS 2: 1200BPS 3: 2400BPS 4: 4800BPS 5: 9600BPS 6: 19200BPS 7: 38400BPS 8: 57600BPS 9: 115200BPS	

This parameter is used to set the data transfer rate between the host computer and the inverter.

Note: The baud rate must be set to the same for the host computer and the inverter, otherwise communication can not be achieved. The larger baud rate, the faster communication speed.

	Data format	Default	0
F9.01	Setting range	0: No parity: Data format <8, N, 2> 1: Even parity: Data format <8, E, 1> 2: Odd parity: Data format <8, O, 1> 3: No parity: Data format <8-N-1>	

Note: The set data for the host computer and the inverter must be the same.

F9.02	This unit address	Default	1
	Setting range	1 to 247, 0for broadcast address	

When the address of this unit is set 0, that is broadcast address, the broadcasting function for the host computer can be achieved.

The address of this unit has uniqueness (in addition to the broadcast address), which is the basis of peer-to-peer communication for the host computer and the inverter.

F9.03	Response delay	Default	2ms
	Response delay	0~20ms	

Response delay: Refers to the end of the frequency converter data to the host computer to send data in the middle of the interval. If the response delay is less than the system processing time, delayed response to system processing time shall prevail, such as response delay is longer than the system processing time, system processed data, to the delay of waiting, until the response delay time to, to send data to the host computer.

F9.04	Communication timeout	Factory value	0.0 s
	Response delay	0.0s(invalid);0.1~60.0s	

When the function code is set to 0.0s, the communication timeout time parameter is invalid.

When the function code is set to a valid value, the system will report the fault fault (Fault sequence number Err.16) if the communication time between the next communication and the next communication time exceeds the communication time. Usually, they are set to invalid. If you are in a continuous communication system, set the secondary parameters, you can monitor the status of the communication.

F9.05	Communication protocol selection	Factory value	1
	Response delay	0: Non standard Modbus protocol; 1: Standard Modbus protocol	

F9.05=1:Select standard Modbus protocol.

F9.05=0:Read command, the return of the number of bytes from the machine is more than one byte of the standard Modbus protocol.

F9.06	Communication read current resolution	Factory value	0
	Response delay	0:0.01A; 1:0.1A	

The output unit of the current value is used to determine the output current of the communication read output.

Appendix II How to use universal encoder expansion card

II-1 Overview

PI500 is equipped with a variety of universal encoder expansion card (PG card), as an optional accessory, it is necessary part for the inverter closed-loop vector control, please select PG card according to the form of encoder output, the specific models are as follows:

Options	Description	Others
PI500_PG1	ABZ incremental encoder: Differential input PG card, without frequency dividing output. OC input PG card, without frequency dividing output.5V,12V,24V voltage is optional, please provide voltage and pulse input mode information when ordering.	Terminal wiring
PI500_PG3	UVW incremental encoder. UVW Differential input PG card, without frequency dividing output.5V voltage	Terminal wiring
PI500_PG4	Rotational transformer PG card	Terminal wiring
PI500_PG5	ABZ incremental encoder. OC input PG card, with 1:1 frequency dividing output. 5V,12V,24V voltage is optional, please provide voltage and pulse input mode information when ordering.	Terminal wiring

II-2 Description of mechanical installation and control terminals function

The expansion card specifications and terminal signals for each encoder are defined as follows:

Table 1 Definitions of specifications and terminal signals

Differential PG card(PI500_PG1)					
PI500_PG1 specifications					
User interface			Terminal block		
Spacing			3.5mm		
Screw			Slotted		
Swappable			NO		
Wire gauge			16-26AWG(1.318~0.1281mm ²)		
Maximum frequency			500kHz		
Input differential signal amplitude			≤7V		
PI500_PG1 terminal signals					
No.	Label No.	Description	No.	Label No.	Description
1	A+	Encoder output A signal positive	6	Z-	Encoder output Z signal negative
2	A-	Encoder output A signal negative	7	5V	Provide 5V/100mA power
3	B+	Encoder output B signal positive	8	GND	Power ground
4	B-	Encoder output B signal negative	9	PE	Shielding terminal
5	Z+	Encoder output Z signal positive			
UVWdifferential PG card					
PI500_PG3 specifications					
User interface			Terminal block		
Swappable			NO		
Wire gauge			>22AWG(0.3247mm ²)		

Appendix II

Maximum frequency			500kHz		
Input differential signal amplitude			≤7V		
PI500_PG3 terminal description					
No.	Label No.	Description	No.	Label No.	Description
1	A+	Encoder output A signal positive	9	V+	Encoder output V signal positive
2	A-	Encoder output A signal negative	10	V-	Encoder output V signal negative
3	B+	Encoder output B signal positive	11	W+	Encoder output W signal positive
4	B-	Encoder output B signal negative	12	W-	Encoder output W signal negative
5	Z+	Encoder output Z signal positive	13	+5V	Output 15V/100mA power
6	Z-	Encoder output Z signal negative	14	GND	Power ground
7	U+	Encoder output U signal positive	15	-	
8	U-	Encoder output U signal negative			
Rotational transformer PG card(PI500_PG4)					
PI500_PG4 specifications					
User interface			Terminal block		
Swappable			NO		
Wire gauge			>22AWG(0.3247mm ²)		
Resolution			12-bit		
Excitation frequency			10kHz		
VRMS			7V		
VP-P			3.15±27%		
PI500_PG4 terminal description					
No.	Label No.	Description	No.	Label No.	Description
1	EXC1	Rotary transformer excitation negative	4	SINLO	Rotary transformer feedback SINLO negative
2	EXC	Rotary transformer excitation positive	5	COS	Rotary transformer feedback COS positive
3	SIN	Rotary transformer feedback SIN positive	6	COSLO	Rotary transformer feedback COSLO negative
OC PG card(PI500_PG5)					
PI500_PG5 specifications					
User interface			Terminal block		
Spacing			3.5mm		
Screw			Slotted		
Swappable			NO		
Wire gauge			16-26AWG(1.318~0.1281mm ²)		
Maximum frequency			100KHz		
PI500_PG5 terminal description					
No.	Label No.	Description	No.	Label No.	Description
1	A	Encoder output A signal	6	A0	PG card 1:1 feedback output A signal
2	B	Encoder output B signal	7	B0	PG card 1:1 feedback output B signal
3	Z	Encoder output Z signal	8	Z0	PG card 1:1 feedback output Z signal
4	15V	Output 15V/100mA power	9	PE	Shielding terminal

Appendix III CAN bus communication card use description

III-1.Overview

CAN bus communication card is suitable for all series of PI500 frequency inverters. Protocol details, please refer to 《CAN bus communication protocol》 document.

III-2.Mechanical installation and terminal functions

III-2-1 Mechanical installation modes:

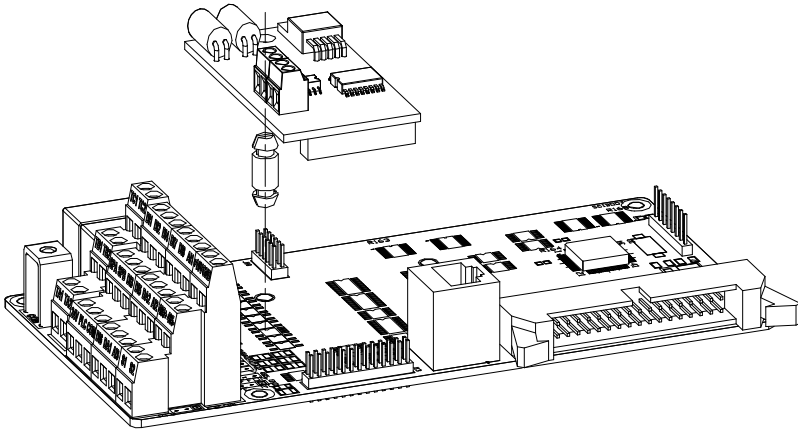

Figure IV-1: CAN bus communication card's installation on SCB

III-2-2 Terminal function

Class	Terminal Symbol	Terminal Name	Description
Communication	CANH	communication interface terminal	CAN communication input terminal
	CANL		
	COM	CAN communication power ground	CAN 5V power output terminal
	P5V	CAN communication power output ground	

Appendix IV: Instruction of Profitbus –DP communication card

IV-1.Outline

9KDP1 meet the international standard PROFIBUS fieldbus, powtran technology PI500 series inverter use it together to achieve the drive to become a part of fieldbus complete control of real fieldbus. Before using this product, please carefully read this manual

IV-2 Terminal function

IV-2-1 DIP switch description

Switch position No.	Function	Instruction		
1,2	DP Card and the drive baud rate selection	Bit 1	Bit 2	Baud Rate
		OFF	OFF	115.2K
		OFF	ON	208.3K
		ON	OFF	256K
		ON	ON	512K
3-8	Profibus-DP Communication from the station address	6 Binary Consisting of 64-bit binary address, more than 64 outside the address can be set only by function code. The following lists some slave address and switch settings Address switch settings 0 00 0000 7 00 0111 20 01 0100		

Table V-1:Switch Functions

IV-2-2 Terminal Function

1) External communication terminal J4-6PIN

Terminal NO	Mark	Function	Terminal NO	Logo	Function
1	GND	5V power ground	4	TR+	Cable Positive
2	RTS	Request to send signal	5	+5V	5Vpower
3	TR-	Cable negative	6	E	The grounding end

Table V-2:External communication terminal function

2) Upper machine communication interface SW1-8PIN

Terminal No	Terminal logo	Function	Terminal No	Terminal logo	Function
1	BOOT0	ARM boot selection	5	PC232T	PC 232 communication Sending side
2	GND	Power ground	6	PC232R	PC 232 communication receiving side
3	VCC	Power	7	RREST	ARM reset
4	Reserved	Reserve	8	GND	Power ground

Table V-3:PC communication terminal function

IV-2-3 LED Light function

LEDlight	Function definition	Description
Green	Power light	If DP card and drive interfaces connected, the inverter after power LED should be in the steady state
Red	DP CARDS and frequency converter serial port connect light	DP Card and inverter connected to the normal state of the LED is lit, flashing indicates the connection is intermittent (For interference), and drive off when a serial connection is unsuccessful (You can check the baud rate setting)
Yellow	DP card and Profibusmain connection indicator light	DP Profibus master card and connect normal state of the indicator is lit. flashing indicates the connection is intermittent (For interference), and Profibus master is off when connection is unsuccessful (you can check the slave address, data formats, and Profibus cable)

Table V-4:LED light function description

Appendix V Product application case

V-1. Single pump constant pressure water supply parameter setting

V-1-1 Electrical Diagram:

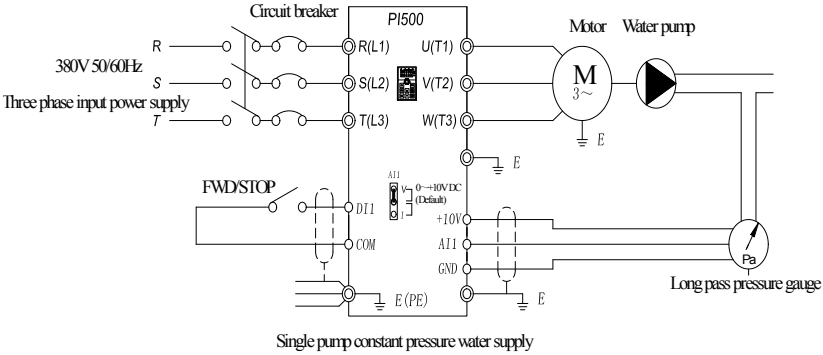

Note: Check the wiring is correct, close the circuit breaker, the inverter power, press the forward button for 1-2 seconds and then stop, check the pump running direction, if the direction is reversed, then change the motor wiring phase sequence

V-1-2 Parameter setting:

No.	Code	Parameter name	Setting range
F0.03	Frequency source master setting	PID control setting	8
F0.11	Command source selection	Terminal block control (LED on)	1
E2.00	PID setting source	E2.01 setting	0
E2.01	PID keyboard reference	0.0%-100.0%	According to the pressure rate to choose the pressure percentage
E2.02	PID feedback source	Analog AI1 reference	0
E2.04	PID reference feedback range	0-65535	Set it according to the on-site pressure
E2.06	PID deviation limit	PID deviation limit	0.2%
E2.27	Computing status after PID stop	PID stop with computing	1
F7.46	Awakens frequency	If the inverter is in hibernation mode and the current running command is valid, when the setting frequency is greater than or equal to the wake-up frequency of F7.46, the inverter will start to start after the delay time of	35.00Hz

		F7.47.	
F7.47	Awakens delay time	0.0s-6500.0s	0.1s
F7.48	Dormancy frequency	During the operation of the inverter, when the set frequency is less than or equal to the sleep frequency of F7.48, after the delay time of F7.49, the inverter will go to sleep state and stop automatically	30.00Hz
F7.49	Dormancy delay time	0.0s-6500.0s	0.1s
FC.02	PIDstart deviation	PID setting start deviation rate	5.0

Note: Under normal circumstances, please set the wake-up frequency greater than or equal to the sleep frequency. Set the wake-up frequency and sleep frequency are 0.00Hz, then sleep and wake-up function is invalid. When the sleep function is enabled, if the PID is used as the PID source, then whether the PID is in sleep mode or not is affected by the function code E2.27. In this case, PID operation must be stopped (E2.27 = 1). E2.01 The method of calculating the signal value given by the keyboard: E2.01 = Set the pressure of the full scale of the pressure gauge * 100%, for example: The full scale of the pressure gauge is 1.0Mpa. If the pressure of the pipe network is required to be constant at 0.4Mpa, The value of E2.01 is 40.0.

V-2 Terminal block control motor forward and reverse

V-2-1 Electrical Diagram:

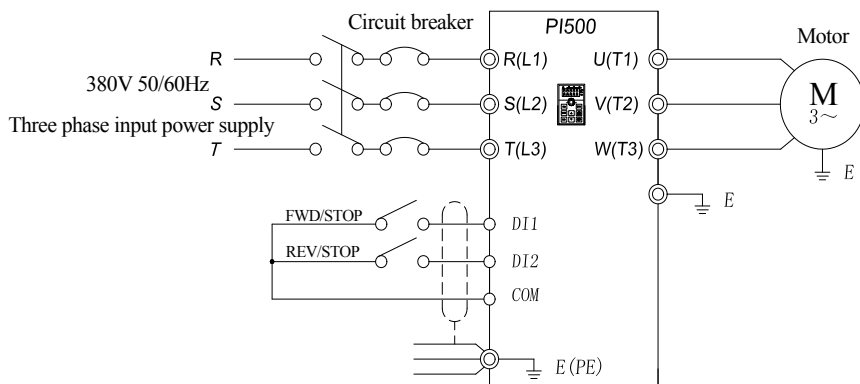

Terminal control control of positive and reverse motor

Connection: Control terminal DI1 corresponds to forward command, control terminal DI2 corresponds to reverse command.

V-2-2 Parameters setting:

No.	Code	Parameter name	Setting range
F0.11	Command source selection	Keyboard control (LED on)	1
F1.00	DI1 terminal function selection	Forward running(FWD)	1
F1.01	DI2 terminal function selection	Reverse running(REV)	2

V-3 External frequency table and ammeter

V-3-1 Electrical Diagram:

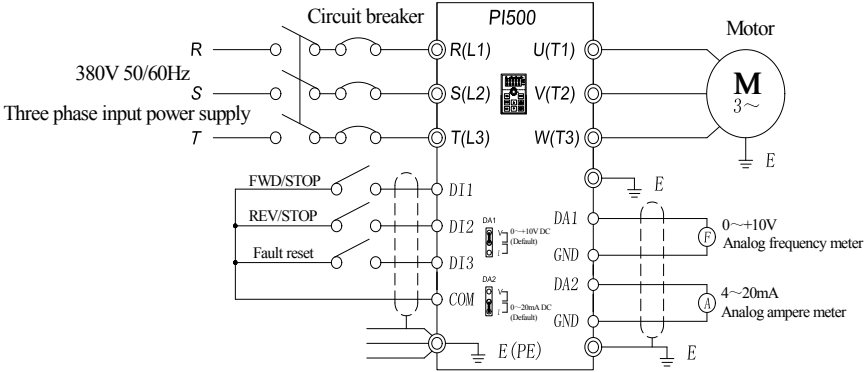

External frequency meter and ammeter

Standard default output: DA1 default 0 ~ 10V; DA2 default 4 ~ 20mA.

V-3-2 Connection:

The frequency meter is connected to the DA1 and GND terminals of the inverter, and the ammeter is connected to the DA2 and GND terminals.

V-3-3 parameter setting:

When the system requires the drive DA1 0-5V signal output, you need to set the parameters as follows:

No.	Code	Parameter name	Setting range
F2.07	DA1 output function selection	Running frequency	0
F2.16	DA1 zero bias coefficient	-100.0%~+100.0%	0%
F2.17	DA1 gain	-10.00~+10.00	0.50

Note: DA1 jumper cap on drive control board needs to be shorted to V terminal.

When the system requires DA2 to provide 4-20mA signal output, the following parameters need to be set:

No.	Code	Parameter name	Setting range
F2.08	DA2 output function selection	Output current	2
F2.18	DA2 zero bias coefficient	-100.0%~+100.0%	20.0%
F2.19	DA2 gain	-10.00~+10.00	0.80

Note: The DA2 jumper cap on the control board of the inverter needs to be shorted to I terminal.

V-4 Terminal block control forward /reverse running jog

V-4-1 Electrical diagram:

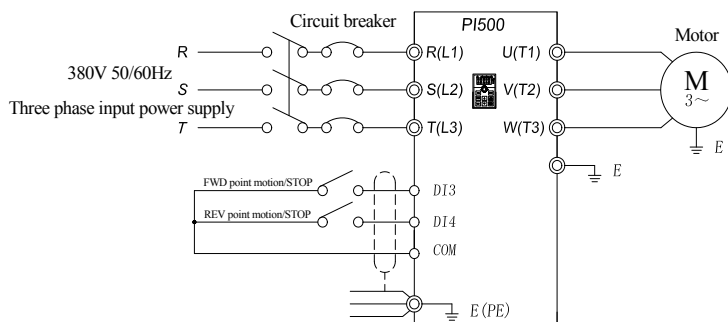

Terminal control to control positive and reverse point movement

V-4-2

Connection:

Control terminal DI3 corresponds to jog command, control terminal DI4 corresponds to Jog command.

V-4-3 Parameter setting:

No.	Code	Parameter name	Setting range
F0.11	Command source selection	Terminal block control (LED on)	1
F1.02	DI3 terminal function selection	Forward JOG(FJOG)	4
F1.03	DI4 terminal function selection	Reverse JOG(RJOG)	5

V-5 Multi-speed running

V-5-1 electrical diagram

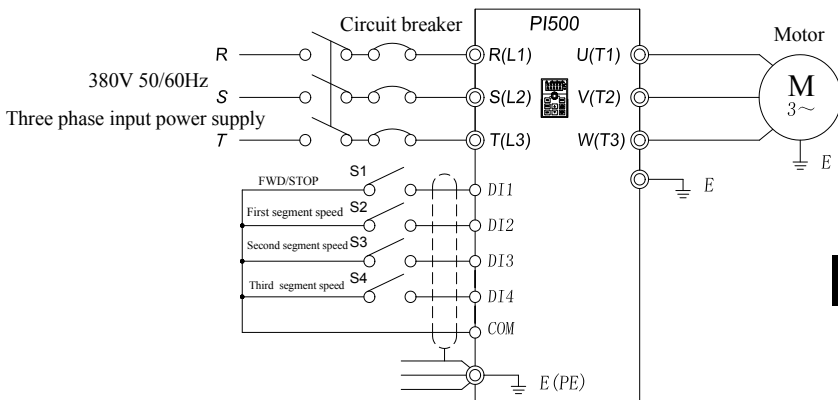

Multi segment speed operation

V-5-2 Connection:

The control terminals DI1 and COM are short-circuited and run forward command (0 segment speed setting 0X). DI2, DI3 and DI4 correspond to 3-segment speed short to COM and 100%

parameter value corresponds to 50HZ.(Take the three-stage speed as an example, up to 16-stage speed control can be realized).

V-5-3 Parameter setting:

No.	Code	Parameter name	Setting range
F0.03	Frequency source master setting	Multi-speed operation setting	6
F0.11	Command source selection	Terminal block control (LED on)	1
F0.13	Acceleration time 1	0.0s~6500s	2.0s
F0.14	Deceleration time 1	0.0s~6500s	2.0s
F1.00	DI1 terminal function selection	Forward run (FWD)	1
F1.01	DI2 terminal function selection	Multi-speed terminal 1	12
F1.02	DI3 terminal function selection	Multi-speed terminal 2	13
F1.03	DI4 terminal function selection	Multi-speed terminal 3	14
E1.00	0-stage speed setting 0X	0-stage speed frequency setting percentage	20.0%
E1.01	1-stage speed setting 1X	1-stage speed frequency setting percentage	40.0%
E1.02	2-stage speed setting 2X	2-stage speed frequency setting percentage	60.0%
E1.04	4-stage speed setting 4X	3-stage speed frequency setting percentage	100.0%
Options:			
E1.51	Multi-stage command 0 reference manner	0 ~ 7 selection, according to the site requirements to set the corresponding way	0

V-6 External potentiometer speed

V-6-1 electrical diagram:

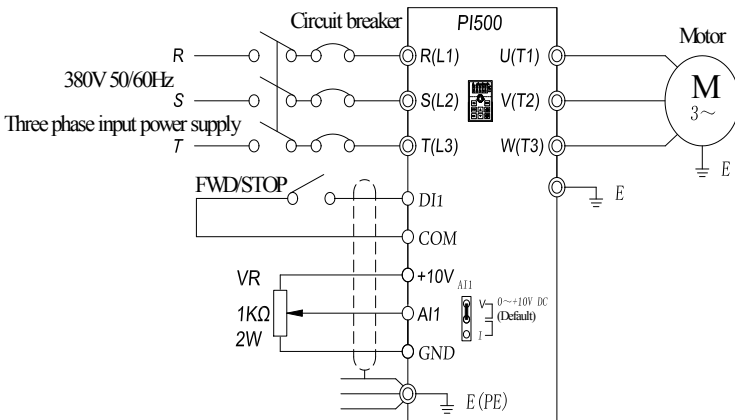

Speed regulation of external potentiometer

V-6-2 connection:

The three cables of potentiometers are connected to the inverter +10 V, AI1, GND terminal, note that the direction of potentiometer wiring, clockwise to the maximum corresponding maximum frequency, counterclockwise twisted to the minimum corresponding 0Hz.

V-6-3 Parameter setting

No.	Code	Parameter name	Setting range
F0.03	Frequency source master setting	Analog AI1 setting	2
F0.11	Command source selection	Terminal block control (LED on)	1
F1.00	DI1 terminal function selection	Forward run (FWD)	1

V-7 Keyboard potentiometer speed**Parameter setting:**

No.	Code	Parameter name	Setting range
F0.03	Frequency source master setting	Panel potentiometer setting	4
F1.42	Keyboard potentiometer X2	0~100.00%	1.00

Note: F1.42 is used to adjust the rate of change of panel potentiometer rotation frequency. The smaller this value is, the more sensitive the panel potentiometer rotation frequency changes.

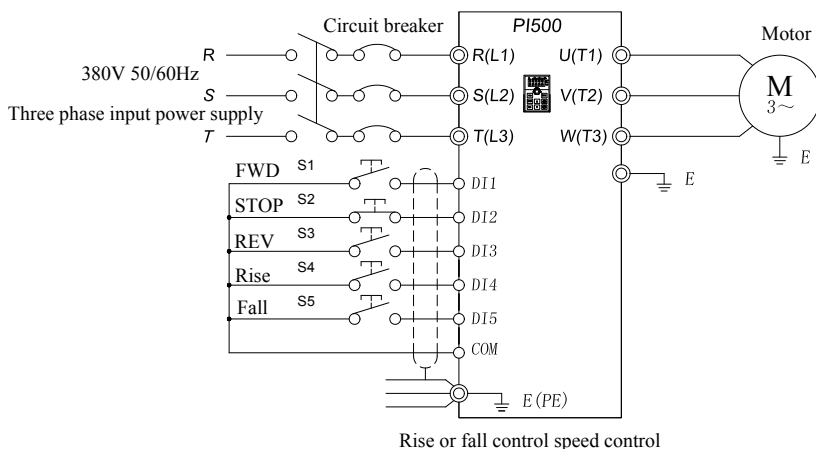
V-8.Rise / Fall Control Speed**V-8-1 electrical diagram:****V-8-2 Connection:**

Three-wire control mode 1, forward command Corresponding terminal DI1, stop DI2, reverse DI3, DI4 and DI5, respectively, with the corresponding COM short rise and fall command.

V-8-3 Parameter setting:

No.	Code	Parameter name	Setting range
F0.11	Command source selection	Terminal block control (LED on)	1
F0.03	Frequency source master setting	UP/DOWN can be modified, power-down without memory	1
F1.10	Terminal command mode	Three-wire control mode 1	2
F1.00	DI1 terminal function selection	Forward run (FWD)	1
F1.01	DI2 terminal function selection	Three-wire operation control	3
F1.02	DI3 terminal function selection	Reverse run(REV)	2
F1.03	DI4 terminal function selection	terminal UP	6
F1.04	DI5 terminal function selection	terminal DOWN	7
F1.11	Terminal UP/DOWN change rate	Used to set terminal UP/DOWN adjustment frequency, the rate of frequency change.	1.00Hz/s
F0.10	UP/DOWN reference	Running frequency	0

V-9. External analog speed control (External 0 ~ 10V voltage signal given)

V-9-1 electrical diagram:

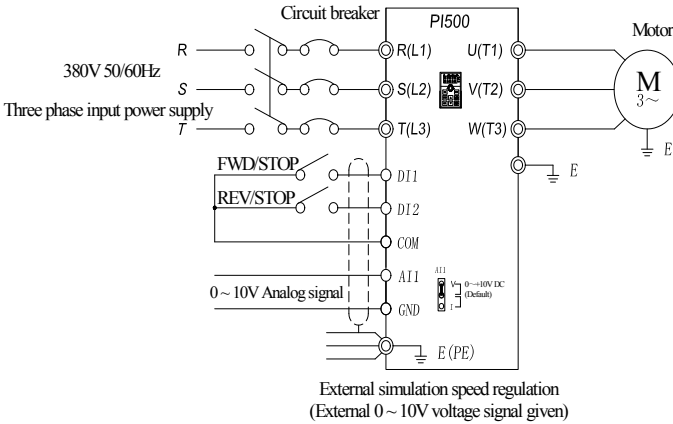

V-9-2 Connection:

The (+) terminal of the external analog signal is connected to the AI1 terminal, and the other terminal of the signal is connected to the GND terminal of the inverter.

V-9-3 Parameter setting:

No.	Code	Parameter name	Setting range
F0.03	Frequency source master setting	AI1 analog quantity setting	2
F0.11	Command source selection	Terminal block control (LED on)	1

F1.00	DI1 terminal function selection	Forward run (FWD)	1
F1.01	DI2 terminal function selection	Reverse run(REV)	2

V-10. External analog speed control (External 0 ~ 20mA current signal given)

V-10-1 Electrical diagram

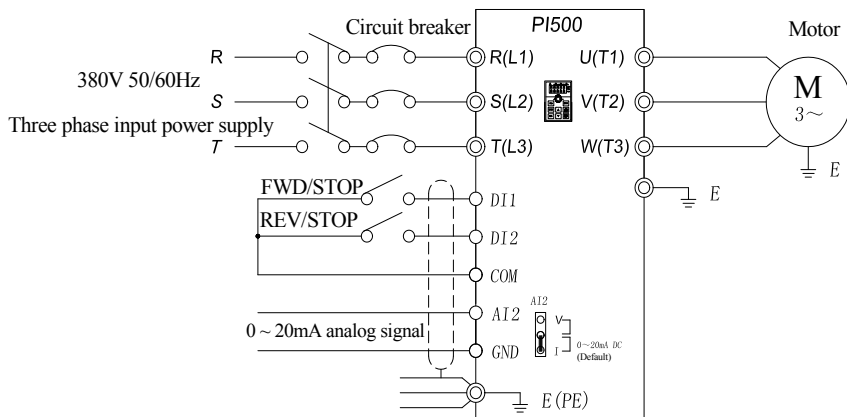

External simulation speed regulation
(external 0 ~ 20mA current signal given)

V-10-2 Connection:

Connect the (+) end of the external reference signal to the AI2 terminal, the (-) end of the signal to the GND terminal of the inverter, and the AI2 jumper cap to the 1 terminal.

V-10-3 Parameter setting:

No.	Code	Parameter name	Setting range
F0.03	Frequency source master setting	AI2analog quantity setting	3
F0.11	Command source selection	Terminal block control (LED on)	1
F1.00	DI1 terminal function selection	Forward run (FWD)	1
F1.01	DI2 terminal function selection	Reverse run(REV)	2
F1.16	Minimum input for AIC2	0.00V-F0.18	0.00V

Note: If external 4 ~ 20mA current signal is given, please set F1.16 = 2.00V.

V-11. Air compressor constant pressure control (Sensor for two-wire pressure transmitter)

V-11-1 Electrical diagram:

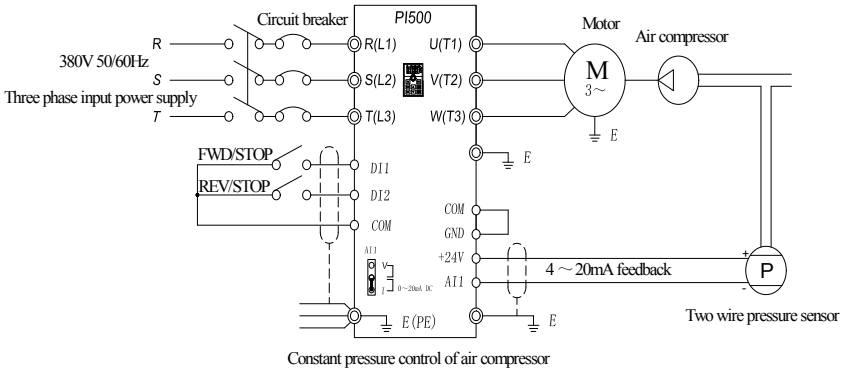

V-11-2 Connection:

Short circuit between COM and GND; +24V, AI1 indirect pressure sensor feedback 4~20mA current signal; DI1, COM indirect "forward / stop" signal, DI2, COM connected to "fault reset" signal; AI1 jumper cap shorted to I end.

V-11-3 Parameter setting

No.	Code	Parameter name	Setting range
F0.03	Frequency source master setting	PID control setting	8
F0.11	Command source selection	Terminal block control (LED on)	1
F0.13	Acceleration time 1	0.0s~6500s	50.0s
F0.14	Deceleration time 1	0.0s~6500s	50.0s
F0.18	Carrier Frequency	0.5kHz~16.0 kHz	4.0 kHz
F0.21	Upper limit frequency	0.00~maximum frequency (F0.19)	48.00Hz
F0.23	Upper limit frequency offset	0.00~Upper limit Frequency (F0.21)	25.00Hz
F1.00	DI1 terminal function selection	Forward run (FWD)	1
F1.01	DI2 terminal function selection	Fault reset	9
F1.12	Minimum input for AIC1	0.5V corresponds to 1mA	2.00V
F3.07	Stop mode	Free stop	1
E2.01	PID keyboard reference	0.0%-100.0%	Set the desired pressure value percentage based on the pressure value

			actually required
E2.29	PID automatic deceleration frequency option	Valid	1
E2.27	Computing status after PID stop	PID stop with computing	1

V-12.Frequency reference mode(External potentiometer, keyboard encoder) switching

V-12-1 Electrical diagram:

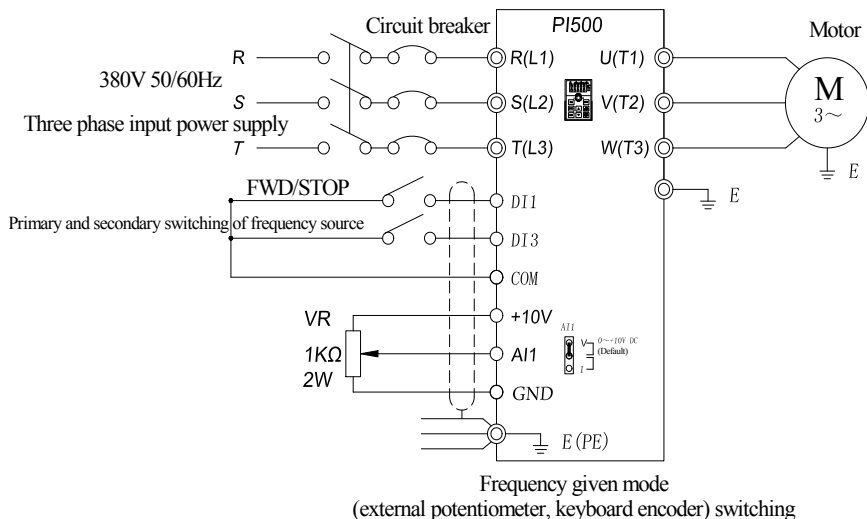

V-12-2 Parameter setting

No.	Code	Parameter name	Setting range
F0.03	Frequency source master setting	Panel potentiometer setting	4
F0.04	Frequency source auxiliary setting	AI1 analog quantity setting	2
F0.11	Command source selection	Terminal block control (LED on)	1
F1.00	DI1 terminal function selection	Forward run (FWD)	1
F1.02	DI3 terminal function selection	Frequency source switching	18
F0.07	Frequency source superimposed selection	Frequency reference main / auxiliary switching	02

Note: DI3 and COM connected to an external potentiometer speed control, disconnect the panel potentiometer speed.

Modified record

Serial No.	Modified date	Modified content record	Modified version
1	2018-01	Appendix V insert v-4-1 terminal block control forward and reverse rotation inching diagram (no figure before) Perfect G6 power model	V2.0
2	2018-03	Add the technical specification and dimension description of plastic shell product G30.75-11kw.	V3.0
3	2018-10	Add 0.4-5.5kw technical specification and dimension description of G1 / G2 derivative product.	V4.0
4	2019-11	1. Size adjustment of G611-187kw after cost optimization 2. TB2 is removed from the control board according to the demand of most customers in the market 3. Add the technical specification and dimension description of G315-22kw plastic shell products	V4.1
5	2021-10	1. The multi speed command table is added on page 30 to facilitate the user's understanding 2. Improve V / F function, add F4.15 ~ F4.20 parameter group 3. Improve the load loss protection, add f8.30 ~ f8.31 function parameters for F8 group fault and protection 4. Add three way hall detection protection, add f8.36 ~ F8.38 parameter group 5. Add the company's QR code to the instruction brand 6. Adjust the optimized size of PI500 045G3 / G4 7. Add special customized product specifications, see page 8 for details 9. The models under the same box in Chapter 7 are distinguished according to the voltage level 10. Add technical specification and dimension description of plastic shell G1 / G2 5.5-11kw	V4.2

Product information feedback

Dear user:

Thank you for your interest in and purchasing Powtran products! In order to better serve you, we want to be able to timely get your personal information and the related information of the purchased Powtran products so as to understand your further demands for our Powtran products, we would appreciate your valuable feedback. For your convenience, please visit our website <http://www.powtran.com> and then click "Technologies and Services" and "Download" columns to submit your feedback information.

- 1) Download the update product manuals you need
- 2) View the technical information on products, such as operation instructions, specifications and features, FAQ, etc.
- 3) Share application cases.
- 4) Technical advisory and online feedback
- 5) Feedback the product and demand information via e-mail
- 6) Inquire the latest products and access to various types of warranty and extend additional services