

Dreieckverschaltung

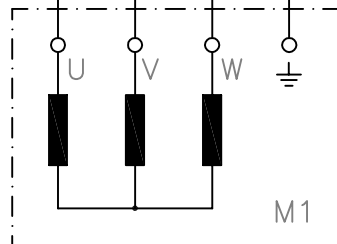

Sternverschaltung

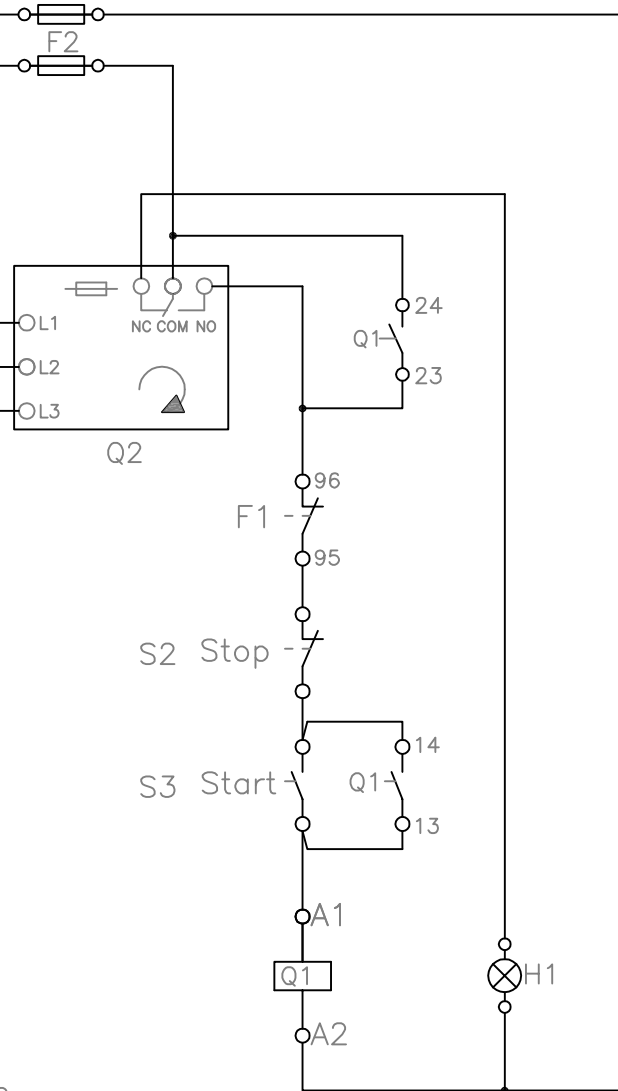

- Komponentenliste:  
 Q1 Schütz Uc:400V~  
 Q2 Drehfeldererkennung 400V  
 F1 Überlastschutz Mx,xA  
 F2 Steuersicherungen F2A  
 S1 Hauptschalter  
 S2 Taster "Stop"  
 S3 Taster "Start"  
 M1 Motor "Stern"  
 M2 Motor "Dreieck"  
 H1 Drehfeldfehler-LED-400V

				Tag	Name	Bezeichnung Drehfeldererkennung
			Bearb.	07.01.15	M.Orlik	
			Gepr.	07.01.15	Treusch	
						ZgNr.
Ind.	Änderung	Tag	Name			e_8700.6000